

## Ultrasonic Wind Sensor

Aluminium Construction, Optional Heating System

### Key Features

- Compact Wind Speed & Direction Sensor
- Hard Anodised Aluminium Alloy Construction
- -40°C Operation (with optional heating)
- IP66 Protection Class
- Vibration BS EN 60945 : 2002
- Impact Resistance to UL2218 Class 1
- Solid-State – Maintenance-Free
- NMEA Output
- Analogue Output (Optional)

The Gill WindSonic M utilises Gill's proven ultrasonic technology that has an established performance over many years of operation in the popular WindSonic.

With an impact resistant, corrosion-free, hard anodised aluminium alloy housing and optional heating system this wind sensor is recommended for use in harsh environmental conditions and is particularly suited to both marine and land based installations. The WindSonic M has no moving parts, offering maintenance-free operation in a wide range of applications.



#### WIND SPEED

Range	0 - 60 m/s (116 knots)
Accuracy	±2% @12 m/s
Resolution	0.01 m/s (0.02 knots)
Response Time	0.25 seconds
Threshold	0.01 m/s

#### DIRECTION

Range	0 - 359° (No dead band)
Accuracy	±3° @12 m/s
Resolution	1°
Response Time	0.25 seconds

#### MEASUREMENT

Ultrasonic Output Rate	0.25, 0.5, 1, 2 or 4 Hz
Parameters	Wind Speed & Direction or U and V (vectors)
Units of Measure	m/s, knots, mph, kph, ft/min

#### OUTPUTS

Digital	RS232 + RS422 + RS485 + NMEA*
Baud Rate	2400 to 38400
Analogue (optional)	0-5v or 0-20mA or 4-20mA

#### POWER REQUIREMENT

Anemometer	5-30V DC (5.5mA @ 12V)
Optional heating**	24V AC/DC (4.2A @ 24V)
	Start up time < 5 seconds
Analogue Outputs	Current consumption increases if analogue output is selected. Add up to 40mA to nominal power consumption above

#### MECHANICAL

External Construction	Al. Alloy 6061 T6
Finish	Hard Anodised
Size	142mm x 160mm
Weight	0.9kg

#### ENVIRONMENTAL

Protection Class	IP66 BS EN 60529 : 1992
Operating Temperature	-40°C to +70°C (with heating) -35°C to +70°C (without heating)
Storage Temperature	-40°C to +80°C
Operating Humidity	< 5% to 100% RH
Precipitation	300mm/hr
EMC	BS EN 61326 : 2006 & BS EN 60945 : 2002
Impact Resistance	UL2218 Class 1
Compass Safe Distance	BS EN 60945: 2002 Section 11.2
Vibration	BS EN 60945 : 2002

#### OPERATIONAL

Warranty	2 years
Factory Calibration	Traceable to National Standards

#### ACCESSORIES

Pipe Mounting	44.45mm (1.75 in) diameter
Windview Software	Display/logging***
Cables	Available to match output options
Display	See Gill display datasheet

\* NMEA 0183

\*\* Consult the technical manual for optimum heating supply voltage.

\*\*\* Download software free from [www.gillinstruments.com](http://www.gillinstruments.com)

## Typical Applications

- Remote weather monitoring stations
- Building controls
- Data buoys
- Marine vessels
- Road & rail tunnels
- Environmental field sites
- Ports & harbours
- Mobile weather monitoring vehicles
- Remote airports & helipads
- Coastal weather monitoring stations

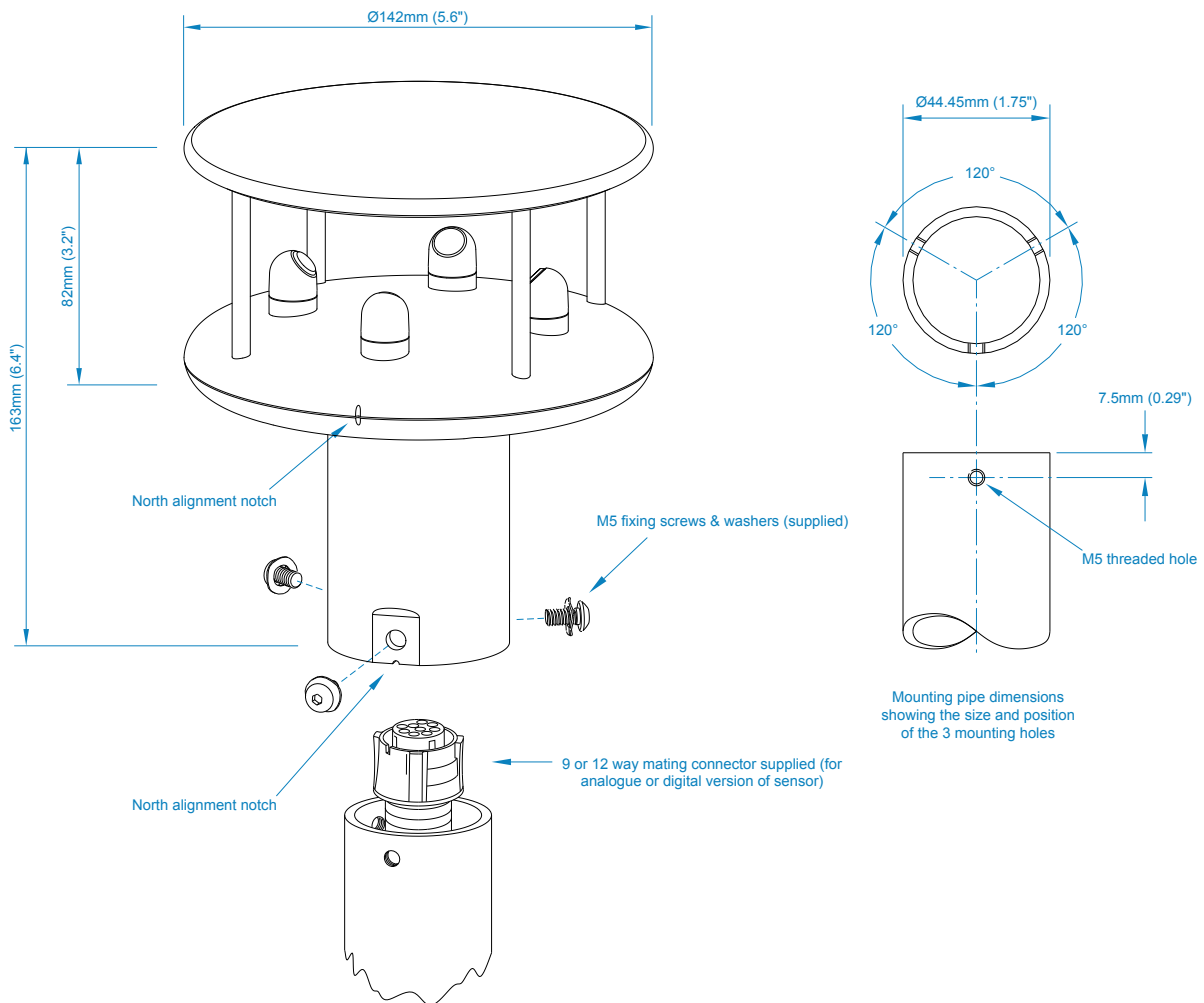

Specifications may be subject to change without prior notice.



# Dynamax



10808 Fallstone Rd #350  
Houston, TX 77099 USA  
Tel: +44 (0) 1590 613 500

admin@dynamax.com www.dynamax.com

1405-0029 - Iss 8

Copyright © Gill Instruments 2013  
Gill Instruments Ltd, Reg No. 2281574