

# GP2 Data Logger and Controller

*Research-grade logger controller - capable of complex calculated measurements and advanced feed-back control*



**User Manual** *version 3.2*

**AT** **Delta-T Devices Ltd**

# Contents

CONTENTS.....	2
UNPACKING .....	4
OVERVIEW .....	5
ABOUT SDI-12 .....	6
DELTALINK SDI-12 TRANSPARENT MODE .....	7
TUTORIALS.....	7
LAYOUT.....	8
INSTALL DELTALINK.....	10
CONNECT TO GP2.....	10
SOURCES OF HELP .....	11
CREATE A SIMPLE PROGRAM IN 6 EASY STEPS .....	12
THE GP2 SIMULATOR .....	13
SAMPLE PROGRAMS .....	14
CHECK SENSOR OPERATION AND START LOGGING .....	14
RETRIEVE, VIEW AND SAVE LOGGED DATA .....	14
TO VIEW DATA IN EXCEL .....	14
SDI-12 CONNECTION .....	15
WIRING AND CONNECTOR REQUIREMENTS .....	17
GIVE EACH SENSOR A UNIQUE ADDRESS.....	20
SDI-12 SENSOR TYPES FOR USE IN DELTALINK.....	23
CREATE A GENERIC SDI-12 MEASUREMENT IN DELTALINK .....	26
TECHNICAL REFERENCE .....	29
SDI-12 INPUT PROPERTIES.....	32
SDI-12 COMMANDS .....	35
SCREW TERMINAL CABLING .....	39
TROUBLESHOOTING .....	41
APPENDIX 1: GP2 RELAY EXPANSION MODULE .....	42

**APPENDIX 2: GP2 NETWORK CABLING ..... 46**

**APPENDIX 3: CABLE EXPANSION LID..... 50**

**APPENDIX 4: WS-CAN CANOPY ..... 51**

**APPENDIX 5: DL-MKT UNIVERSAL DATA LOGGER MOUNTING KIT..... 52**

**APPENDIX 6: M-ENCL-B2 ENCLOSURE WITH MODEM GATEWAY TO DELTALINK CLOUD..... 53**

**APPENDIX 7: MAKE SURE THE GP2 IS PROPERLY SEALED..... 54**

**APPENDIX 8: UPGRADE GP2 FIRMWARE ..... 55**

**GP2 SPECIFICATIONS ..... 56**

**PRODUCT CARE AND MAINTENANCE ..... 64**

**GP2 CALIBRATION CERTIFICATE ..... 64**

**LEGAL AND REGULATORY ADVICE ..... 64**

**WARRANTY AND SERVICE ..... 65**















**INDEX..... 67**

# Unpacking





The GP2 package contains:

- GP2 Logger (with 6AA batteries to be fitted by the user)
- **GP2-USB** USB cable for GP2
- This GP2 User Manual
- Screwdriver and cable gland spanner

## Accessory Options

<p><b>GP2-RLY</b> Relay Expansion Module - 4 extra relays and power terminals</p>	
<p><b>WS-CAN</b> an open Protective Canopy with U-bolts and logger mounting kit for GP2 or DL2e loggers</p>	
<p><b>M-ENCL</b> lockable enclosure</p>	
<p><b>DL-MKT</b> Universal Mounting Kit – a flat plate with U-bolts, nuts and bolts for GP2, GP1 and DL6 loggers</p>	
<p><b>GP2-G5-LID</b> Expansion Lid with 5 cable glands for 3 to 10 mm dia. cables</p>	
<p>5-way M12 connector (f) 5m cable to 100mm long flying leads with bare wires <b>SMSC/sw-05</b> for connecting SDI-12 network of EXT/5W-xx cables to GP2 logger</p>	
<p>5-way M12 serial communication + power extension cables (<b>EXT/5W-xx</b> where xx = 1, 5, 10 or 25m)</p>	
<p><b>GP2-NTP</b> 5-pin network T- Piece with continuous screen, for connection of loggers and EXT/5W-xx cables. Can be used for logger comms and power networks (joining multiple loggers together) or SDI-12 network</p>	
<p><b>GP2-STP1</b> 4-pin network T-Piece for networking of SDI12 sensors and EXT/5W-xx cables. <b>Not to be used for logger communication networks. Only for sensor SDI-12 networks.</b></p>	
<p><b>GP2-NPC</b> Network Power Cable – to supply power via a GP2-NTP and/or EXT/5W-xx cable</p>	
<p><b>GP2-USB</b> USB cable, 1.5m</p>	
<p><b>GP2-RS232</b> RS232 cable, 1.5m</p>	
<p><b>GP2/GP1-M8</b> network adapter cable, 1m</p>	
<p><b>GP2-PSU</b> Mains Power Supply<sup>1</sup> with mains cable <b>PC-XX</b> where XX = UK, EU, US, IN or CN</p>	

<sup>1</sup> Not weatherproof, for indoor use only

<p><b>CON/5W-M-S-LD</b> In-line M12 male 5-way connector to screw terminals, with screened metal shell, for connecting SDI-12 sensors fitted with screened cable to GP2 logger. Accepts cable 4-9 mm diameter.</p>	
<p><b>CON/5W-M-NS-SD</b> In-line M12 male 5-way connector to screw terminals, with unscreened plastic shell, for connecting SDI-12 sensors fitted with unscreened cable to GP2 logger. Accepts cable 3-6.5 mm diameter.</p>	
<p><b>CON/5W-M-NS-LD</b> In-line M12 male 5-way connector to screw terminals, with unscreened plastic shell, for connecting SDI-12 sensors fitted with unscreened cable to GP2 logger. Accepts cable 4-8 mm diameter.</p>	
<p><b>GP2-SER</b> Service Pack:- battery holder, desiccant, cable gland bungs &amp; seals, lid screws, wire links, screwdriver, and dust cap on lanyard</p>	

Plugs with screw connectors are available for adding to the M12 connector system.

## Overview

- The GP2 has 12 differential analogue input channels<sup>2</sup>, four event/digital counter channels, and a serial input channel for up to 62 SDI-12 sensors or a single WET sensor.
- Two output relays can be extended to 6 using a relay expansion module.
- Two banks of terminals provide a 3V precision reference, or unregulated power for sensors. There is also one 5V and one 12 V power terminal.
- Each sensor can be read at a different rate, from 1 second to >1000 days.
- Multiple recording rates are possible for any combination of measurements.
- Multiple recording types are provided:- average, minimum, maximum, total, integral, wind-rose, conditional.
- The logger can hold about 2.5 million readings.
- Each relay can control a separate experiment, zone or test protocol, each based on different threshold settings or conditional logic.
- Simple programs are quickly created on your PC, assisted by the sensor library and a helpful user interface, and then sent to the logger.
- Sophisticated program scripts can be created without having to learn a programming language or typing out any commands.
- New measurements can be created mathematically along with complex control algorithms, using algebraic and trigonometric functions and conditional logic, with easily created sequences of instructions.

<sup>2</sup> or 24 single-ended analogue channels – but note the limitation on the number of cable glands.

- You can create and manipulate your own “variables” for e.g. disease risk factor, integral error, days since soil moisture below a threshold, etc.
- Thresholds can be changed while logging, by using program settings.
- A simulator assists the checking and understanding of the behaviour of logging and control programs. A weather pattern can be repeated, or new one randomly created. It is particularly useful for irrigation.
- Video tutorials, online help, a sensor library and friendly user interface are provided for the DeltaLINK 3 software.

## **Sensors Supported**

- All Delta-T sensors. Many third-party sensors, including SDI-12.
- User defined sensors based on voltage, current, resistance, bridge, potentiometer, counter, frequency and digital state sensors.
- Any number of calculated measurements.

## **About SDI-12**

SDI-12 is a communication protocol which enables sensors with a built-in microprocessor to share a single 3-wire cable to send data to a data logger. SDI-12 stands for serial digital interface at 1200 baud.

It is widely used by the water industry, typically for monitoring water catchment areas and for measuring soil moisture and other environmental data.

## **Features and Benefits of SDI-12**

- Reduced system costs.
- Simplified and lower cost cabling requirements (can be 3-core)
- Use of a single data logger for multiple sensors on one cable
- Power is supplied through the same cable.
- Sensors can be interchanged without re-programming the logger with calibrations and other parameters.
- Use of a 'standard' interface eliminates complexity in logger design.
- Level of interoperability between different manufactures' devices.
- Battery powered operation, with minimal current drain.
- The SDI-12 standard enables a sensor to store and provide some meta-information about itself (e.g. manufacturer, product name, serial number). This can be of benefit in permitting the interchangeability of sensors and obtaining higher accuracy.

## **GP2 SDI-12 Features and Benefits**

- SDI-12 measurements are available for recording and processing in DeltaLINK 3.2, alongside 'conventional' analogue and digital measurements. They can be:
  - added to recordings
  - used in Scripts, Conditions, and Calculations
  - viewed via Read Now, to check sensor operation.

- Many third-party SDI-12 sensors are predefined in a sensor library add-in for DeltaLINK. They are easily added to a program, but first each needs a unique address. (The GP2 SDI-12 Transparent Mode is suitable for doing this)
- SDI-12 cuts down the amount of sensor cable you need – one daisy chain instead of a star network.
- Delta-T's cabling with 5-way M8 connectors can be used.
- The same cable can supply 12V power to all the sensors.
- Up to 62 SDI-12 sensors can be connected to a GP2 logger in addition to its standard analogue and digital sensors (limited by the number of SDI-12 addresses available, cable length, program measurements and GP2 memory).
- Up to 300 different measurements can be recorded at a time (limited by the GP2's capability) .  
For example, you can connect up to 50 PR2/6 6 channel sensors.
- The serial communications format avoids many of the problems typically associated with long cable runs from sensors with analogue output signals.
- The SDI-12 protocol allows for the use of self-calibration algorithms within the sensor itself.
- Existing GP2s are in-field upgradeable (no need to return to Delta-T):
- The existing Delta-T M12 x 5-way cable system can be used.  
See page 15.
- Re-wireable connectors (i.e. with internal screw-terminal connectors) are available to interface 3rd party sensors to the Delta-T cable system.
- Re-wireable connectors are also available to interface the PR2 SDI-12 sensor with third party loggers.  
See page 39.

## DeltaLINK SDI-12 Transparent Mode

Type in commands to a sensor via a command box and see it reply in an output box. This way you can do the following:

- Discover and change a sensor address.
- Change a sensor configuration.
- View optional diagnostic detail.
- Power up the SDI-12 bus.

When you issue a command, the logger turns on the SDI-12 power supply before sending the command.

If a sensor takes longer to power up the logger re-issues the command.

See DeltaLINK's context sensitive online **Help**.

## Tutorials

See **GP2 Intro Series Tutorials** at

<http://www.youtube.com/user/DeltaTDevices/videos>

# Layout

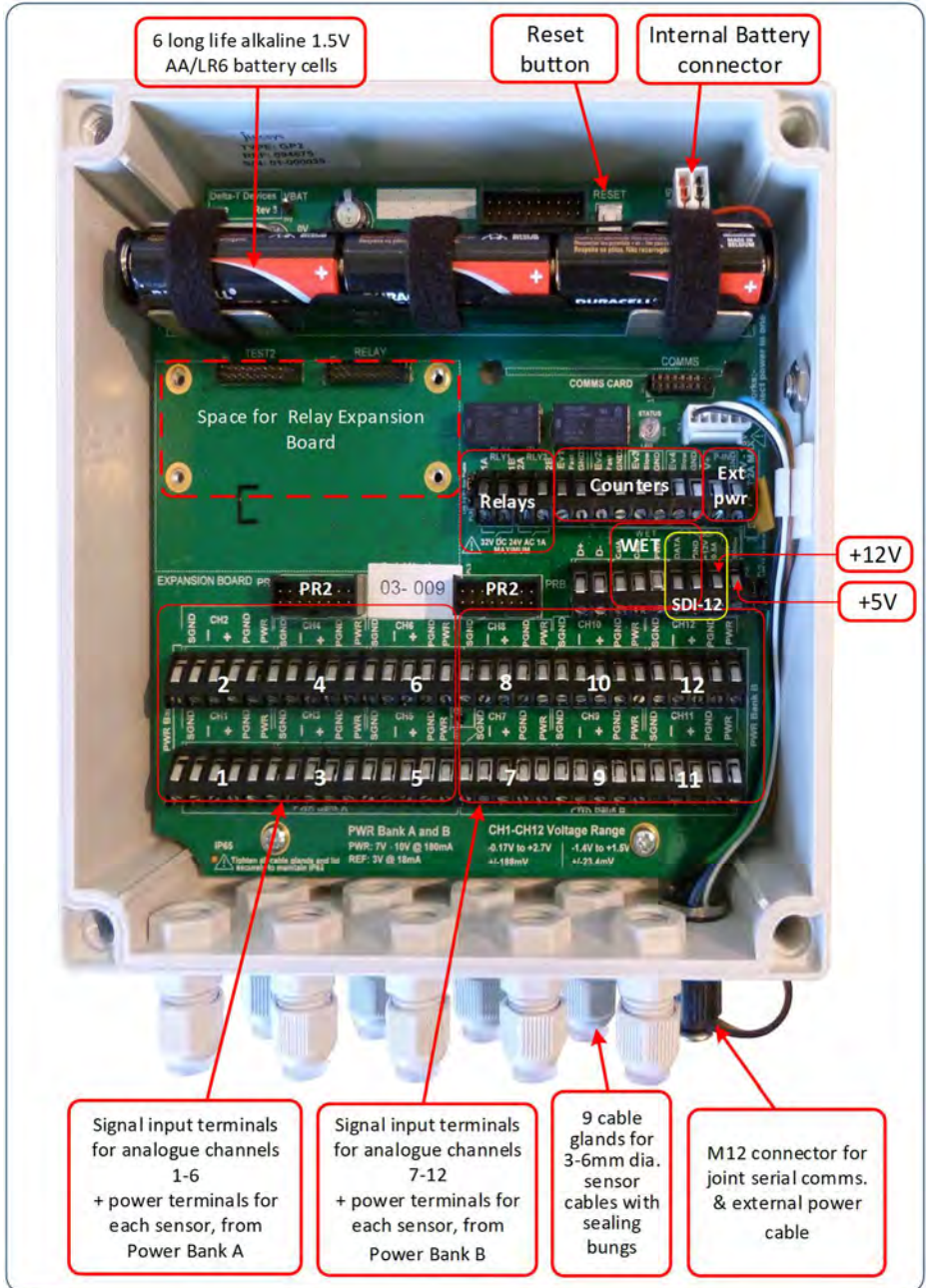

## Event Channels

Use **Event 1** or **2** to monitor fast switch closures or pulses up to 30 kHz, such as a flow meter.

Use **Event 3** or **4** to monitor slower switch closure or pulses <100Hz, such as a rain gauge. A 5ms de-bounce feature reduces the risk of double counting.

## Relay Channels

The **Relay** channels have an open or closed latching switch, protected with a resetting thermal-fuse. They can be used in a variety of ways, e.g. to control several different experiments or irrigation zones, or alarms, or to switch power to sensors.

Each relay can switch up to 1A at 24VAC or 32V DC.

See also the Relay Expansion Module on page 42.

## Status LED

**Two** flashes per ten seconds means the GP2 is **logging**.

**Four** flashes in a group indicate an **error**.

**No flash** means **not logging** or **no battery** power.

If the logger locks up, briefly press the **Reset** button.

After pressing **Reset**, 4 LED flashes indicate that the GP2 is doing a **warm reset**.

Your program and data are preserved and logging will resume.

Hold **Reset** for more than 5 seconds until a second set of four LED flashes occur to initiate a **cold reset**. This restores the factory-set default program and deletes all data including any program which you may have added.



After releasing the button, there is a short delay (a few seconds) before the logger starts erasing the flash. The LED flashes continuously whilst the logger is busy doing this. Wait for this flashing to end, and don't press any button or try to communicate with the logger - it could take up to a minute. This confirms the cold boot was successful and is complete.

## Analogue Channel Considerations

The differential analogue channels accept signals nominally 0 to 2.5V, with a full signal range of -1.4 to +2.7V.

The input range of custom sensor types can be set to auto-range or to fixed ranges.

Ensure each voltage input on the (+) or (-) terminals is kept within the permitted common mode range of -2.5V to +3V relative to logger GND. Ensure these limits are not exceeded, particularly if powered sensors are not powered by the GP2. The input signal may need to be connected to the logger ground. If the signal is floating then place a 10kohm resistor between (-) and (SGND).

## Sensor Power

Analogue channels have (PWR) terminals to allow power to be switched to sensors. Sensors can be powered with an adjustable warm-up time prior to taking a reading. The duration of the warm-up period can be increased in multiples of one second.

Input	
Input type	Voltage
Channel	Ch 1
Input range	Auto
Open circuit detection	-0.27V to 2.7V
Power channel	±1.5V
Calculation	±185mV
Result	±23mV
	Auto

PWR on Bank A	
	None
★	PWR on Bank A
	PWR on Bank B
	PWR WET
	REF3V on Bank A
	REF3V on Bank B
	+5V
	+12V
	RLY1
	RLY2
	RLY3
	RLY4
	RLY5
	RLY6

The PWR power terminals associated with channels 1 to 12 can supply a regulated or unregulated voltage.

On Bank A and B the GP2 can provide either 3V ( $\pm 0.2\text{mV}$ ) or 5 to 10.5V (unregulated). In addition, 5V ( $\pm 2\%$ ) and 12V ( $\pm 0.4\text{V}$ ) DC are available on separate screw terminals. External power can also be switched to sensors via the two internal relays and four extra relays of the Relay Expansion Module.

The WET sensor PWR terminal also supplies 5.0 to 10.5 VDC unregulated and can be used by another sensor if no WET sensor is connected.

## Install DeltaLINK

To operate the DeltaLINK 3 software for the GP2 logger you need:

- A PC running Windows 10 or later.
- One free USB or RS232 port.
- Internet connection for software install.
- GP2 to PC USB cable (supplied with GP2).

1. Obtain DeltaLINK 3 from <http://www.delta-t.co.uk>.

**Read the Release Notes** in the **Document Library** or at <http://www.delta-t.co.uk>.

2. Select **Install DeltaLINK** and follow the on-screen instructions.

3. Setup creates a desktop shortcut to **DeltaLINK** and puts a **Firmware Upgrade** program, a **GP2 Calibration Certificate Generation** program, and a **Document Library** folder in the DeltaLINK 3 program group.

4. Install USB drivers for the cable. See <https://ftdichip.com/drivers/vcp-drivers/> and FAQ "How do I set up my USB to RS232 Converter?" at <https://delta-t.co.uk/frequently-asked-questions/set-usb-rs232-converter/>.

## Connect to GP2

1. Connect GP2 to the PC using the USB cable provided (ensure drivers are installed, see above).
2. Run DeltaLINK.
3. If DeltaLINK discovers your logger, it displays this in the status bar – see at right.
4. If the GP2 is not found select **Connection Details, Add, Details, Detect USB Port** or select the correct COM port from the drop down list.

See *How to find your USB COM port* on page 49 .

If using networked loggers see page 48.

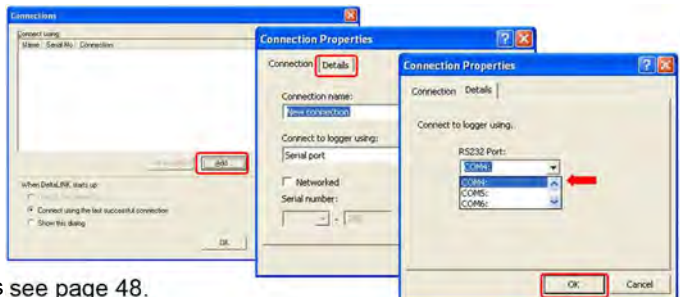
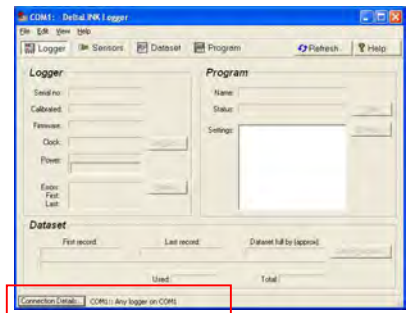

# Sources of Help

## Online Help

Click **Help** from any DeltaLINK window (or press F1) in selected areas for context sensitive information about DeltaLINK operation and functionality.  
Select **Start, All Programs, Delta-T Devices, DeltaLINK, Document Library**.

## Video Tutorials

Before attempting to program the GP2 watch the video tutorials – at <http://www.youtube.com/user/DeltaTDevices/videos>.

These tutorials show the progressive development of a soil moisture sensor program, followed by its use to control soil moisture using an irrigation control relay. Run DeltaLINK at the same time and see if you can reproduce the instructions along with the instructor.

## Sensor Wiring Instructions

Wiring, installation and programming notes are provided for all sensors in the GP2 sensor library. This information appears in the Info Panel when a sensor is selected in the **Measurement** section as shown in Step 2 below, Left click on the wiring diagram to enlarge it. If wiring up in the field, it may help to have these printed - see steps 3 & 4.

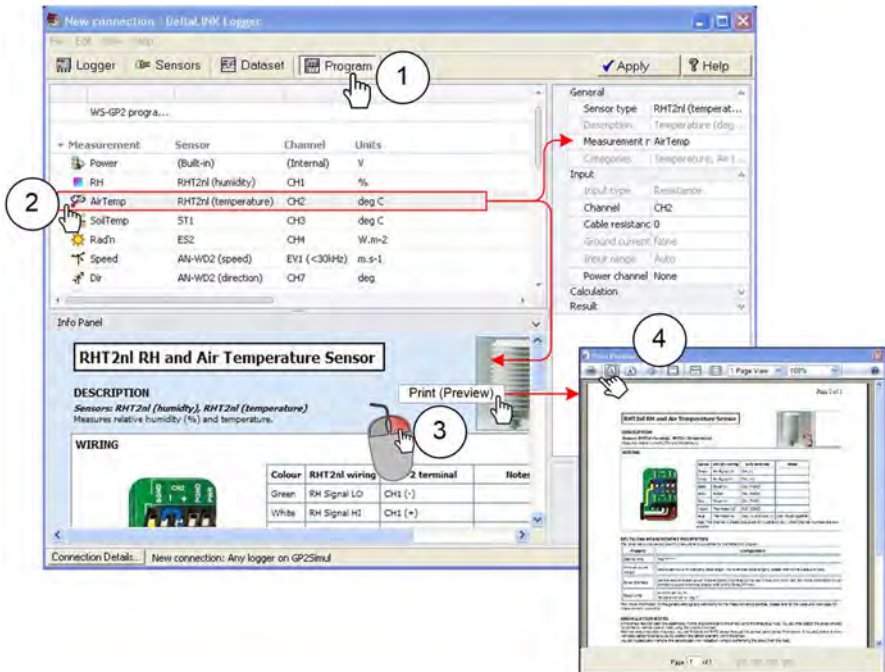

# Create a Simple Program in 6 Easy Steps

Before you start you need to have DeltaLINK connected to your GP2 (see above), or to the GP2 Simulator (see below).

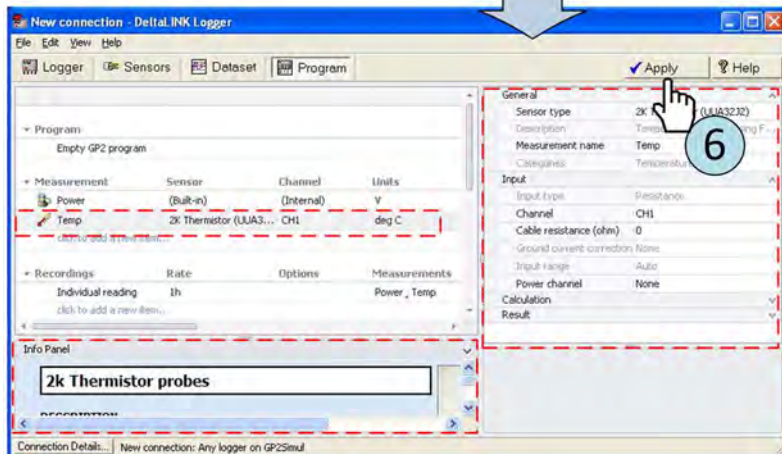
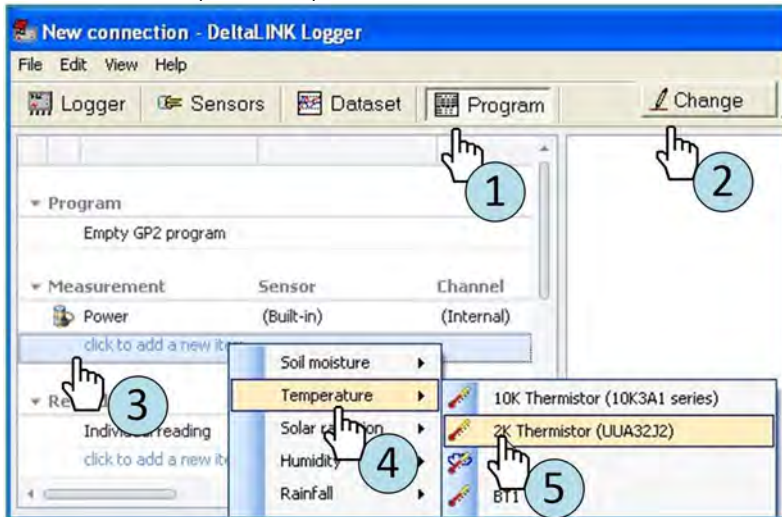

1. Select **Program**
2. Select **Change**
3. Click on “**Click to add new item**, under **Measurement**.”
4. Select **Temperature** (or any other option from the list)
5. Select **2K Thermistor** (or any other option)
6. Select **Apply** to send the program to your GP2 or the simulator

You can now, if you wish, click on the **Sensors** tab and **Read Now** to watch real-time readings, or select the **Logger** tab and **Start Logging**.

Note after step 5 above, the icon and label for the sensor appear in the **Measurement** list in the left hand window. Also, detailed properties for the chosen sensor appear in the right hand window, including the channel number, and, as we saw earlier, the sensor connection instructions appear in the lower left **Info Panel**.

Under **Recording** the row labelled **Individual reading** indicates a rate of once per hour. To change this, select the row – which will open the recording options on the right hand panel, and choose your own Recording rate.

Note: Before you can change a program, stop logging and delete the logged data (select **Logger**, **Stop** then **Delete Records**).

## The GP2 Simulator

This simulates the weather and its effect on a variety of sensors. Before sending a program to your logger, try it out on the Simulator.

You can speed up time in the simulator to check the behaviour of your program.

Restart the simulator and it will recreate the same weather as before, from the same date. This lets you see the effect of changes to a program.

(Note the simulated weather uses an artificial pattern and pseudo-random numbers, so don't rely on it for anything important.)

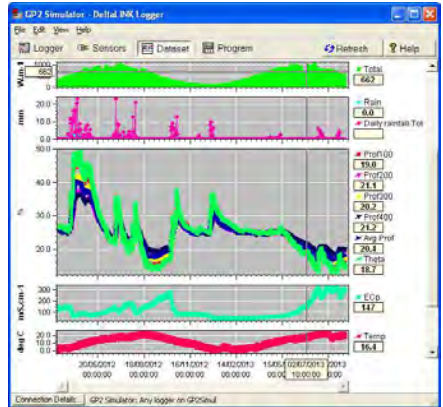

Graphs of solar radiation, rain, soil moisture, salinity and temperature generated by the DeltaLINK Simulator

## Connect to GP2 Simulator

- 1) Ensure DeltaLINK is connected to the GP2 Simulator as follows:-
  - a) Select **Connection Details, Add** and on the **Connection Properties, Connection** tab set **Connect to logger using** to **Simulator**
  - b) On the **Details** tab set **Select simulator model** to **GP2 simulator**.
- 2) Click on **OK**, then **OK** again to connect

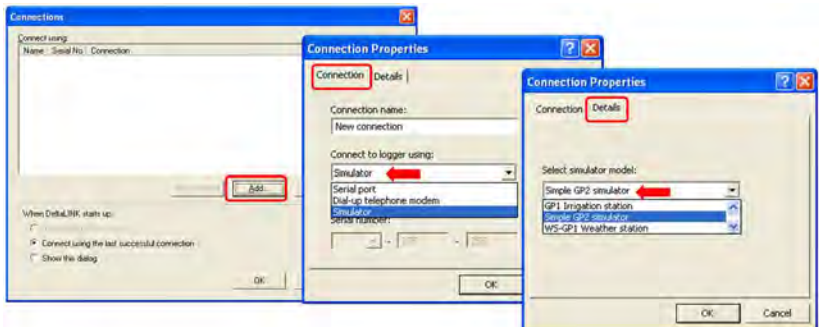

# Sample Programs

Several are provided. To use these go to the Program tab, click on the **Change**, select **Edit, Import Sample Program**, and select one from the **Open** dialog.

## Check Sensor Operation and Start Logging

1. Select the **Sensors** window and click the **Read now** button. The sensor readings will continually refresh on a scrolling time graph.
2. Observe the sensor reading display in the scrolling charts and value panels while adjusting sensor wiring and/or installation conditions.
3. Click the **Cancel** button when finished.
4. Once sensors are setup select the **Logger** tab and click **Start** to commence logging.

## Retrieve, View and Save Logged Data

1. Select the **Dataset** window. All stored data in the logger will be retrieved and displayed on the screen. Click **Refresh** if required.
2. Select **File, Save** to save the data to a dataset file on your PC.

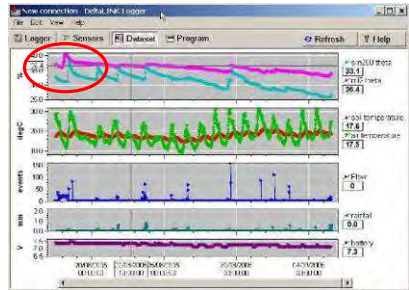

## To view data in Excel

This helps import logged data files into MS Excel spreadsheets.

1. Open a previously saved (see above) dataset file (\*.dt6 file extension).
2. Select **File, Save As** to change the file to a \*.csv format for opening in Excel:

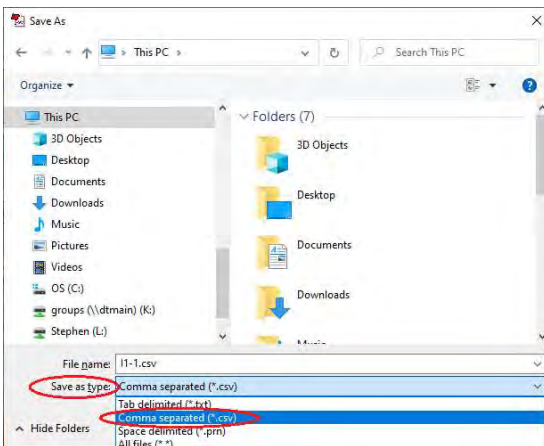

# SDI-12 Connection

Ensure you are running the latest version of DeltaLINK and have firmware 2.1 or later. If you need to upgrade the firmware, please refer to the instructions in Appendix 8.

## Cabling Connection Options

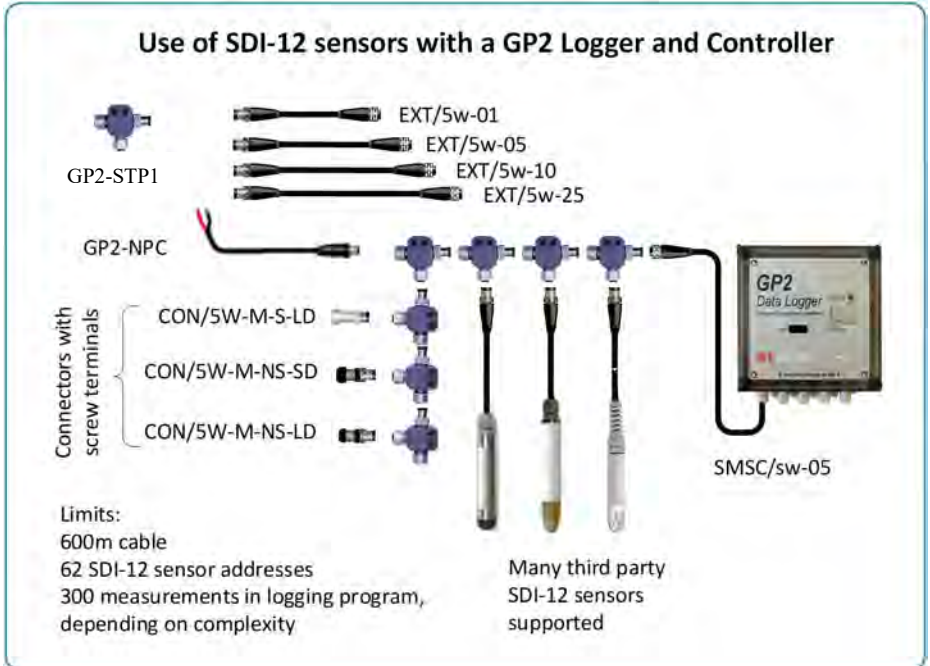

Figure 1: Wiring system used to connect SDI-12 sensors to the GP2 Logger controller, using cables with integral 5-way M12 connectors.

You can use this system to reliably connect 10 SDI-12 sensors on a total cable length of 600m (2000 feet). In many cases more sensors and/or longer cable lengths are possible.

## M12 Connector tightening

### **\*\*Warning\*\***

When connecting multiple cables and T-piece together, it is essential that any M12 connector is tightened sufficiently:

- Ensure internal connector O-ring and opposite sealing face are free from dirt.
- Tighten the connector thumbscrews as much as you can by hand or use a torque driver set to 1Nm to be sure. See video:



M17 koneksi dengan network

<https://youtu.be/BLo1k5fYqao>

We recommend the Weidmuller “1900021000” torque driver:



This will save lots of painstaking trouble shooting hours if you do have a loose connection and give you piece of mind that all connectors are correctly tightened.

- Untightened connectors can come undone and let water into the cable network which can damage cores and cause erroneous readings.



# Wiring and Connector Requirements

SDI-12 uses a 3 wire cable with sensors attached along it – as in a daisy chain. The wires are used for Power (12V DC), Ground (0V) and Serial Data (5V).

The SDI-12 specification states...

*“The SDI-12bus is capable of having at least 10 sensors connected to it, each with 200 feet of cable. With fewer sensors, longer cable lengths are possible.”*

But note also...

*“...the voltage drop between the data recorder and all sensors [should be] less than 0.5 volts during the maximum combined sensor current drain.”*

For further technical detail on requirements see SDI-12 standard (v1.3) at [www.sdi-12.org](http://www.sdi-12.org)

## Worked Example of an SDI-12 Cable Length Calculation

The SDI-12 cable provided by Delta-T has a resistance of 0.06 ohms per metre, so to meet the 0.5V voltage drop restriction the maximum length of cable, in metres, between each sensor and the GP2 is

$$1000 * 0.5 / (0.06 * I_{ma}) = 8333 / I_{ma}$$

...where, for **Sequential** measurements (see page 32),  $I_{ma}$  is the sensor supply current in mA when it is active.

For **Concurrent** measurements  $I_{ma}$  is the combined active supply current of all sensors in a Concurrent group (see page 32) and the formula provides a worst case estimate of maximum length of cable between the GP2 and the most distant sensor in the Concurrent group.

For further technical detail on requirements see SDI-12 standard (v1.3) at [www.sdi-12.org](http://www.sdi-12.org)

## Wire SDI-12 network cable to GP2 logger controller

Wire colour SMSC/sw-05	GP2 terminal	Function	M12 Connector Pins
Black	SDI-12 DATA	SDI-12 Data	4
Blue	GND	Sensor ground power return	3
Green		Screen	Screen
White	12V	Sensor power	2

## SDI-12 Power supply requirements

GP2 provides switched +12V @ 500mA either from its internal batteries or from an external source.

To avoid rapidly depleting the GP2 battery an external GP2 power supply is recommended if sensors need several 10's of mA or are intended to operate below 10 °C.

Alternative methods of powering sensors are:-

- Use of GP2 relays to switch in external power.
- Permanent power supply to sensors which don't tolerate power cycling.

## ***SDI-12 to GP2 logger wiring connections- using logger power***

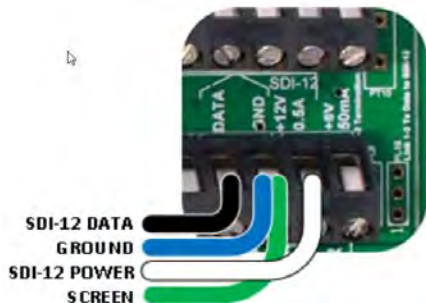

Figure 2: Sensor connection to the SDI-12 channel in the GP2 logger, using the logger's internal 12V Power channel.  
Colours shown are for cable type SMSC/sw-05.

## ***SDI-12 to GP2 logger wiring connections- using external power***

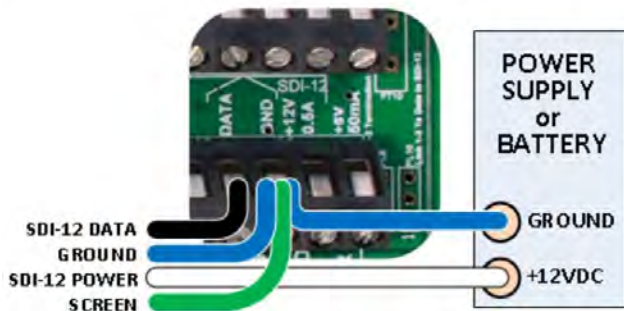
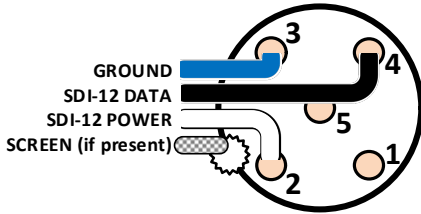
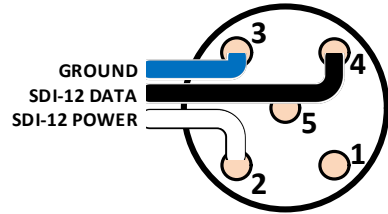

Figure 3: Sensor connection to the SDI-12 channel in GP2 logger, using an external permanent (i.e. un-switched) power supply or battery connection.  
Colours shown are for cable type SMSC/sw-05.

## M12 connector sensor wiring connections for SDI-12



4a. Pin connections for connector type CON/5W-M-S-LD, for sensors with screened cable\*



4b. Pin connections for connector types CON/5W-M-NS-(LD or SD) for sensors with unshielded cable

Figure 4: Pin connection diagrams for field attachable 5-way M12 connectors used as part of the Delta-T M12 SDI-12 cabling system to connect to the SDI-12 channels of the GP2 logger as shown in in Figures 2 or 3

\*Note: When using screened cable take care to clamp the screen securely to the metal shell of the connector.

See also **Screw terminal cabling** on page 39.

# Give each Sensor a Unique Address

## Know this

Give each SDI-12 sensor a unique address **before** connecting it into a network of other SDI-12 sensors.

Delta-T DeltaLINK Logger software provides a mean for doing this, called the **SDI-12 Transparent Mode**.



---

Note: If two sensors have the same address the SDI-12 network will not work.

---

A new sensor will typically have the address set to 0 (number zero).

Give each sensor a unique address.

This can be one of the following 60 addresses:-  
0 to 9, a to z, or A to Z.

(Other printable characters such a punctuation marks are permitted but think carefully before using such characters).

## Open DeltaLINK Transparent mode

You need a GP2 connected to a PC running DeltaLINK v3.2 or later.

With no other sensors on the network connect the sensor to the GP2 SDI-12 channel.

In DeltaLINK select **Tools**, **SDI-12**, **Transparent mode** to open the SDI-12 Transparent mode terminal as shown below.

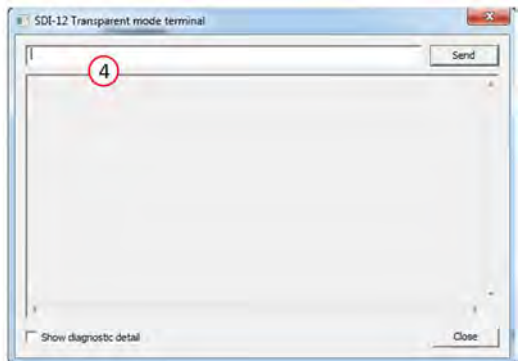
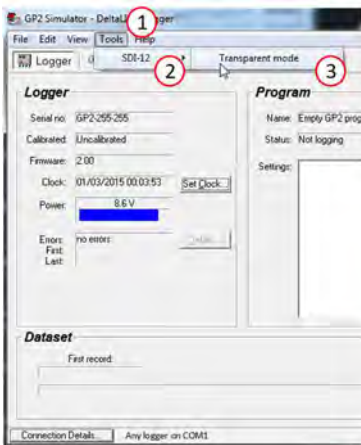

Once the SDI-12 Transparent mode terminal is open, as shown above, the GP2 behaves as a transparent serial link between sensors on the SDI-12 network and the PC.

## About the SDI-12 Transparent Mode

The SDI-12 Transparent mode terminal can be used to make changes to sensor configurations and discover and change their address.

Use this terminal window by typing in the command box at the top, and the response from the sensor will be displayed in the output box below.

When you issue a command the logger with turn the 12V power supply on before sending the command.

Some sensors takes longer to power-up, and so you will see the logger resend the command. It will also add the command terminator "!" if you forget it.

Here the output box shows the logger tried 7 times before the sensor has replied - with address "0".

Ensure only one sensor is connected on the SDI-12 network.

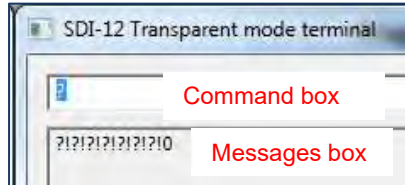

### Example: Use Transparent Mode to set an address:

We assume the SDI-12 Transparent mode in DeltaLINK, Tools has been selected, as shown above, and is running, so your PC keyboard is communicating transparently through the GP2 directly with the SDI-12 network.

We also assume you only have one sensor on the SDI-12 network, and it is your new sensor, and we want to give it a unique new address.

#### 1. Display sensor's address using the Query "?!" command.

This identifies the address of a sensor.

The sensor must be alone on the bus ... otherwise all sensors will 'shout at once' and send their own address.

In the Transparent mode command box type **?!** followed by Enter.

In the output box you see<sup>3</sup> the following response from the sensor

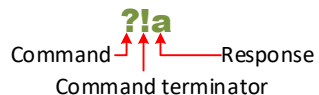

We would normally expect this address to be zero for a new sensor, but it might not be.

Here the address reported is "a" (It could be a-z, A-Z or 0-9)

You may already have another sensor with this address.

<sup>3</sup> There is also a hidden <Carriage Return> <Line Feed> string at the end of each message, which just acts to display the next reply on a new line.

## 2. Confirm it works: tell sensor to identify itself.

The command **I!** displays a sensor's identification: manufacturer's name, model and other details.

Note: SDI-12 commands are case sensitive.

Note: All SDI-12 commands start with an address (apart from **?**) and finish with **!** DeltaLINK is quite forgiving and will add the terminating **!** if you forget.

You type	a!
Response	a13Delta-T PR2SDI00200000000010001

The logger asks the sensor at address "a" to identify itself.  
It replies with a long string of characters which is **different for each manufacturer.**

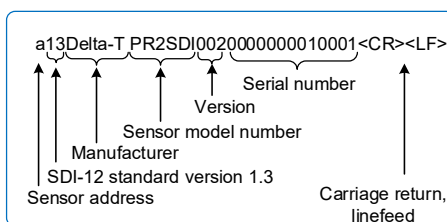

## 3. Change its address

You type	aAb!
Response	b <CR><LF>

Your sensor now has the address "b"



Before putting a sensor on the SDI-12 network ensure it has a unique address, or you will bring the network down.

## SDI-12 Sensor Types for use in DeltaLINK

A custom SDI12 Sensor Library resource file containing a range of other manufacturer's sensors is freely available for download from the Support/ Software Downloads pages at [www.delta-t.co.uk](http://www.delta-t.co.uk).

We provide this free of charge and have confirmed that the sensors work with the GP2 but we make no claims on the suitability of the sensors or the sensor type code and do not generally provide technical support for them.

Generic SDI-12 sensor types (powered and unpowered) are provided in DeltaLINK. These can be copied and adapted to suit your sensor. You will need to read the supplier's data sheets and may also need to read the SDI12 standard at [www.sdi-12.org](http://www.sdi-12.org).

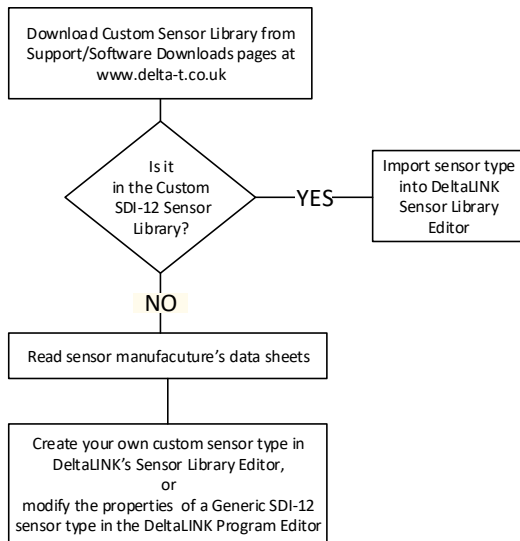

**Figure 5 Decision Tree on obtaining Sensor Types for DeltaLINK for use with SDI-12 sensors from other manufacturers.**

## Import the Custom SDI-12 Sensor Library

- 1) Ensure the latest version of DeltaLINK is installed on your PC.
- 2) Connect a GP2 running firmware version 2.10 or later, or select **Edit, New Program, GP2 Multifunction Program**.
- 3) Select **Program** tab and wait for the current program to appear.
- 4) Select **Edit, Sensor Library Editor**.
- 5) Select **Edit**.

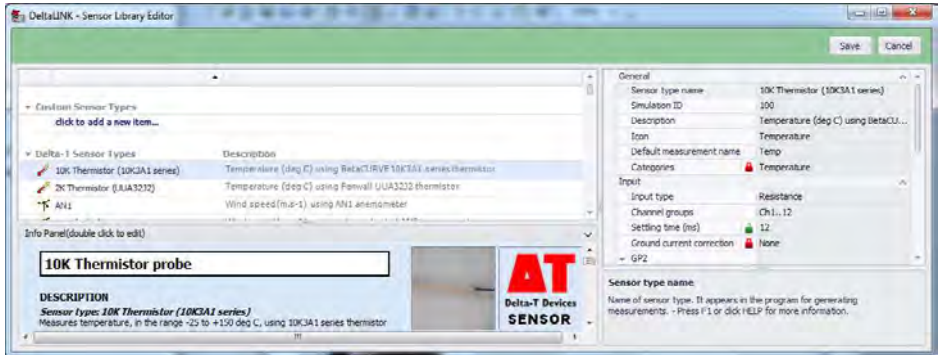

- 6) Under Custom Sensor Types, **Right** click to display a list of options

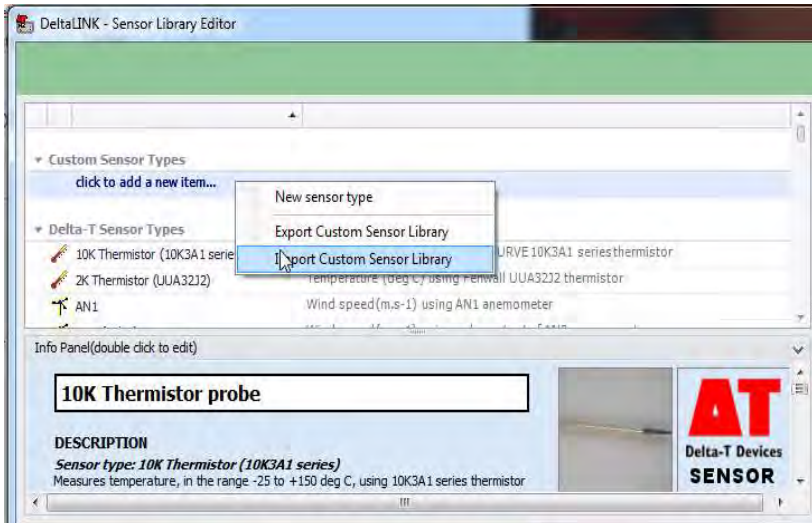

- 7) Select **Import Custom Sensor Library**.
- 8) Browse to the downloaded copy of the sensor library file and click on **Open**.

- 9) Choose and select which sensors you wish to import and click on **Import selected sensor types**.
- 10) Click to close message announcing the process succeeded and examine the sensors now listed under Custom Sensor Types in the Sensor Library Editor.

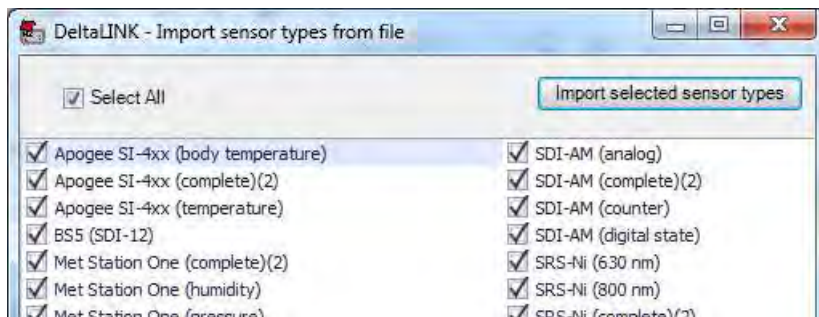

## Custom SDI 12 Sensor Types

Custom Sensor Types	Description
Apogee SI-4xx (body temperature)	Body temperature (deg C) using Apogee SI-400 series Infrared Radiometer
Apogee SI-4xx (temperature)	Target temperature (deg C) using Apogee SI-400 series Infrared Radiometer
BSS (SDI-12)	Barometric pressure (hPa) using Delta-T BSS5 barometer
Met Station One (humidity)	Relative humidity (%) using Met Station One weather station
Met Station One (pressure)	Barometric pressure (hPa) using Met Station One weather station
Met Station One (supply voltage)	Power supply voltage to weather Met Station One (V) using Met Station One weather station
Met Station One (temperature)	Temperature (deg C) using Met Station One weather station
Met Station One (wind direction)	Wind direction (deg) using Met Station One weather station

**Figure 6 SDI 12 Sensor types as displayed in DeltaLINK after importing the entire SDI 12 library.**

Note: This list is liable to change without notice. One example of each third party sensor is tested to see if it worked with a GP2 but Delta-T do not distribute and do not support them.

The one exception to this rule is the BSS5 pressure sensor, which we do sell and support.

# Create a Generic SDI-12 measurement in DeltaLINK

1. Start **GP2 Program Editor**.
2. Click **Change**.
3. In **Measurements** list select **Click to add a new item**.
4. Select the **Generic** menu.
5. Select **SDI-12, powered** or select **SDI-12, not powered** if providing an independent (i.e. not switched) power supply.

Note: Each GP2 measurement holds a single value. Multiple GP2 measurements are required to hold a collection of values from a multi-parameter sensor.

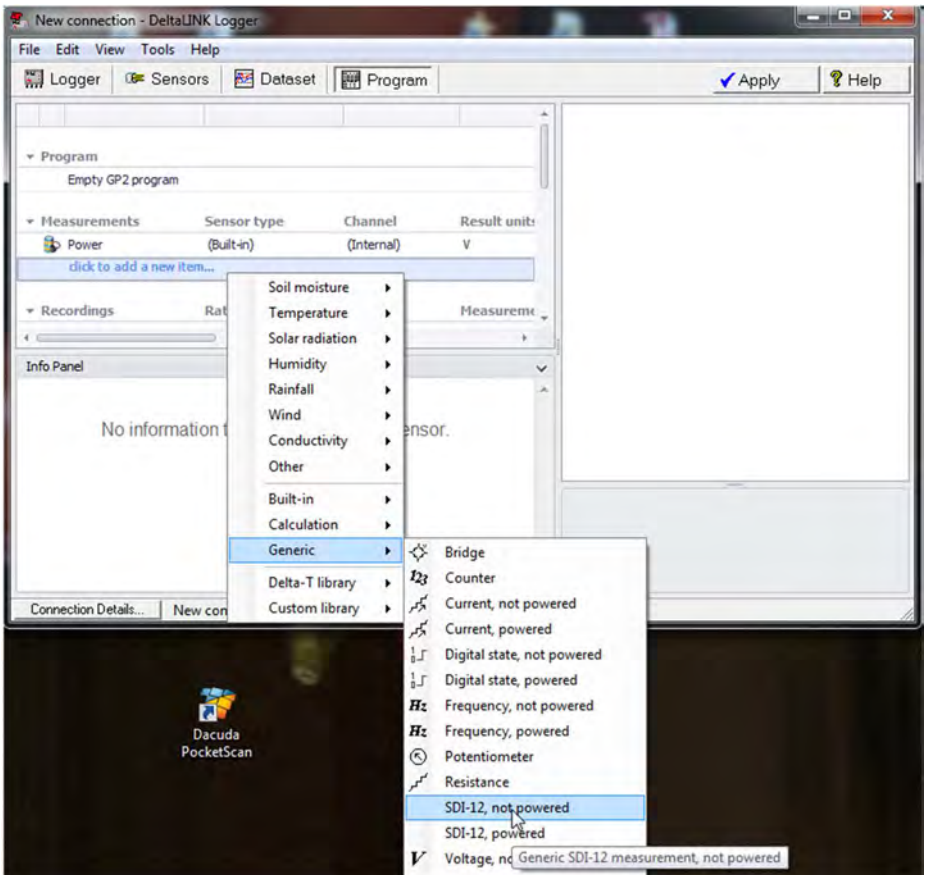

## Set Measurement's Input Properties

To continue you may now need to cross-refer to the references section on **SDI12 Input Properties** on page 32

In particular **you must set the correct address** for the sensor (see 6 below).

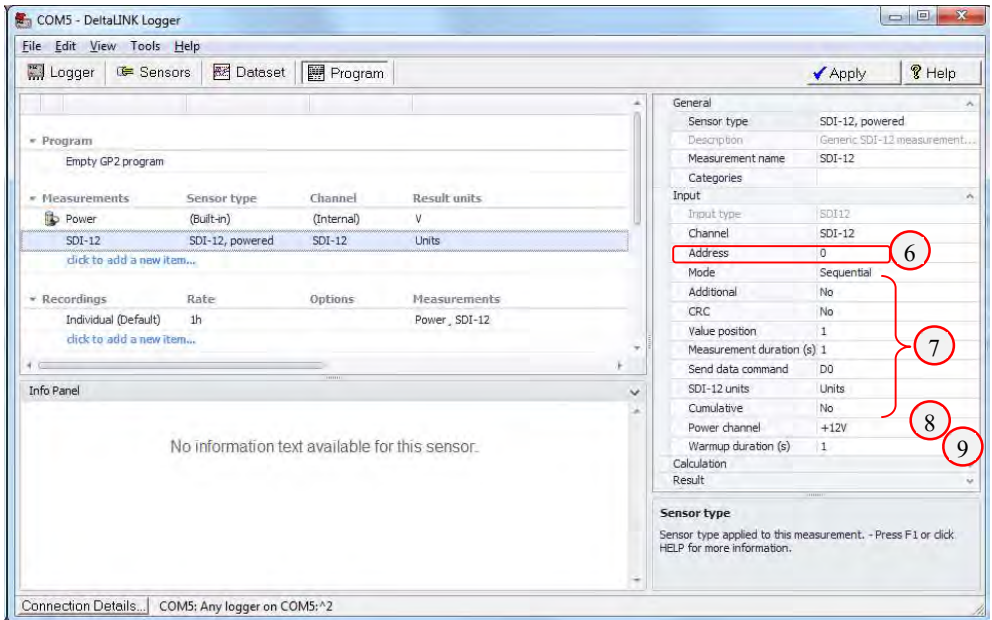

Here an SDI-12 measurement has been added.

On the right, in the Properties panel, you can see the sensor measurement properties, including **Input** properties:

Some settings are common to all measurements such as Measurement name, Calculation, Result, Power channel, Warmup duration, Sensor type, Input type, and Channel are given default options by DeltaLINK.<sup>4</sup>

6. Earlier, using the DeltaLINK SDI-12 Transparent mode you should have ensured the SDI-12 sensor has a unique address, see page 20. Now set the measurement input **Address** field to the same address.
7. **Refer to the sensor manufacturer's data sheets** for information on the other SDI-12 properties that need to be set. See also:

**SDI-12 Input Properties** on page 32

SDI-12 Standard (v1.3) at [www.sdi-12.org](http://www.sdi-12.org)

8. Specify the **Power channel**.  
The GP2 **+12V** supply is designed for SDI-12 sensors.  
All other options are available, including the use of relays to switch an external supply.

<sup>4</sup> Requires DeltaLINK 3.2 or later.

- Specify the **Warmup duration**. This defines the time between the turn on of power and the sensor being able to receive commands. Do not confuse it with the Measurement duration. Sometimes this is not specified in data sheets. Use 1s unless a sensor requires longer than this.

## Set Calculation and Results Properties

Expand the Calculation and Results properties by clicking on the down arrow as displayed the right.

The default measurement calculation offered by the generic DeltaLINK SDI12 Measurement is displayed. It says “No calculation” which means that DeltaLINK will simply pass on the measurement it receives from the SDI12 sensor.

From here on the SDI12 sensor output can be treated like any other sensor connected. So at this stage if you wish you can use the full power of the GP2 to do complex maths on this measurement.

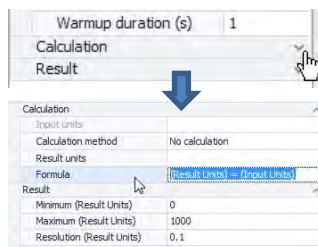

## Result properties

As with all DeltaLINK sensor measurements ensure the permitted range resolution needed for your readings are appropriate.

For further help highlight a parameter and then press F1.

## Logging interval

The minimum logging interval may vary depending on how many sensors you have connected to the SDI-12 network. DeltaLINK gives you an option of logging every 1s, which may be fine for analogue readings but not with SDI-12.

SDI-12 sensors can have a measurement duration which may last longer than 1s. In addition to this it is prudent to allow at least another half a second per SDI-12 measurement.

If a reading cannot complete in the time available, then the previous SDI-12 reading for that sensor will be reported. So one way of discovering how fast you can take reading is to vary the relevant environmental parameter increasingly quickly and find out at what recording rate the readings fail to keep up with the rate of change.

# Technical Reference

## GP2 Program and Sensor Library Editor

In the **GP2 Multifunction Program Editor**, the Measurements list pop-up menu offers Generic SDI-12 Sensor types ('powered' and 'not powered' variants). SDI-12 Sensor types, from other suppliers are available for importing into the sensor library. These are free to download from the Support/Software Download pages at [www.delta-t.co.uk](http://www.delta-t.co.uk).

To import these into the **Sensor Library Editor** click **Edit**, right-click in **Custom Sensor Types** and select **Import Custom Sensor Library**.

These all have 'SDI-12' as their Input type, a collection of SDI12-specific properties (such as SDI-12 Address) which can be assigned in the same way as properties of other Input types, together with the same General, Calculation and Result properties as other measurements.

Measurements based on these SDI-12 Sensor types can then be selected in Recordings, and entered into Custom formulae, Conditions and Scripts in the same way as other measurements.

In the Sensor Library editor, the 'SDI-12' Input type can be selected to create custom SDI-12 sensor types.

SDI12-specific properties allow default or 'Additional' SDI-12 measurements to be selected, in Sequential or Concurrent mode (i.e. aM, aMn or aC, aCn commands), with or without CRC<sup>5</sup>. Each GP2 measurement holds a single value, so the position in the list of values returned by the sensor has to be specified. Multiple GP2 measurements are required to hold a collection of values from a multi-parameter sensor.

The GP2's +12V output is intended for powering the SDI-12 bus and can source 500 mA. Other GP2 outputs can be selected as the Power channel, or <none> if using an independent power supply. Concurrent measurements can be assigned to 'Concurrent groups', which are measured separately, to avoid overloading the SDI-12 power supply.

## SDI-12 firmware operation

GP2 Programs perform program actions (Recordings, Scripts, etc.) on 1s clock ticks. This means that all measurements which the program needs to process need to be complete within 1s of the time when they are due. Thus for analogue measurements, the GP2 schedules warmups to occur in advance so that sensors are powered up, settled and ready to be measured when required.

Similarly, the GP2 accommodates SDI-12 measurements, which can take several seconds (or even minutes) to complete, by performing them in advance. This ensures that measurement values are ready for processing when required, but there is inevitably a delay between the measurement itself and the time when it is used by the program. The SDI-12 'bus latency' is the maximum delay incurred by any SDI-12 measurement: it is the time required to complete all the SDI-12 measurements in the program, plus a contingency for retrying – as explained below.

---

<sup>5</sup> Cyclic Redundancy Test is a method of checking the reliability of serial data

In general, the delay between any SDI-12 measurement and the time when its value is used in the program may be as long as the bus latency – but no longer. If a program requires SDI-12 measurements more frequently than the bus latency, it may use duplicate values – but these will be no older than the bus latency. Similar behaviour occurs in DeltaLINK's 'Read Now', where duplicate values are shown until an updated value becomes available.

The SDI-12 specification stipulates that a SDI-12 recorder is required to retry several times if a command does not receive an error-free response. The GP2 provides a contingency for retrying, so sequences of SDI-12 measurements normally complete several seconds before the programmed time. It is not practical to allow for the worst case – where all SDI-12 commands fail in the most time-consuming manner. The time allocated by the GP2 for retries guarantees a 99.99% success rate, if 10% of SDI-12 commands randomly fail.

## ***Transparent mode terminal***

A Transparent mode terminal is a requirement of the SDI-12 specification, and is normally required at least to configure the addresses of SDI-12 sensors.

The **Tools > SDI-12 > Transparent mode** command opens the 'SDI-12 Transparent mode terminal' window. Type a SDI-12 command in the command box, click Send and observe the response in the output box.

If the GP2 is programmed for SDI-12 measurements and a Power channel is selected, the GP2 activates the SDI-12 Power channel before transmitting the command. Otherwise, the GP2 activates the default +12V output.

The command is transmitted immediately, so if a sensor is slow to start up, the command may fail. The Power channel remains powered for 30s after completing any command, so clicking Send a 2nd time normally succeeds.

The GP2 transmits the command, including <break> and retries, according to the rules of the SDI-12 protocol. The output box displays all SDI-12 commands and responses.

Enable 'Show diagnostic detail' to view timings and result codes for each transmitted command.

## ***SDI-12 Sensor requirements***

Sensors should conform to the SDI-12 standard v1.3 at [www.sdi-12.org](http://www.sdi-12.org).

Some third party sensors can be unstable unless powered continuously.

These can be accommodated by arranging the sensor cabling with two power lines, one switched by the logger, the other permanently connected to a second supply.

Each SDI-12 sensor must be assigned a unique address before putting it on the SDI-12 network. This can be done using the DeltaLINK Transparent Mode.

# Versions

SDI-12 support is introduced in GP2 firmware version 2.10, which is distributed as the firmware upgrade in DeltaLINK 3.2.

	DeltaLINK 3.2		DeltaLINK 3.1.1		
	Firmware	2.10	2.00	2.10	2.00
• <b>Logger and Sensors views, Read Now</b>		✓	✓	✓	✓
• <b>Datasets</b>		✓	✓	✗	✓
• <b>Programs, View and Save</b>		✓	✓	✗	✓
• <b>Programs, Change and Apply</b>		✓	✗	✗	✓

# Compatibility

GP2 programs created in DeltaLINK 3.2 require GP2 firmware 2.10 (or later), and are not compatible with earlier firmware versions.

Datasets created by firmware 2.10 require DeltaLINK 3.2 (or later) and are not compatible with earlier DeltaLINK versions.

DeltaLINK 3.2 installs 'side by side' with earlier DeltaLINK versions, so an earlier version can be retained for working with earlier GP2 firmware versions.

All GP2s are built with SDI12-capable hardware and firmware 2.10 is fully compatible with all existing GP2s.

# SDI-12 Input Properties

## Channel groups (in Sensor Library editor)

Select the SDI-12 sensor channel group to **SDI-12**.

### Address

Select the SDI-12 address of the sensor.

Each SDI-12 sensor must have a unique address. Type the aAn type command in the DeltaLINK's SDI-12 Transparent mode terminal to set a sensor's SDI-12 address.

See also **Give each Sensor a Unique Address** on page 20

### Mode

Select **Sequential** or **Concurrent**.

In Sequential mode, the sensor will be the only active SDI-12 sensor when making its measurements; all other SDI-12 sensors will be in low-power quiescent mode.

In Concurrent mode, other SDI-12 sensors can be active and making measurements at the same time.

Concurrent mode speeds up throughput of SDI-12 measurements because it allows sensors to make measurements in parallel. However, this requires all active sensors to be powered up at the same time and may impose a large load on the SDI-12 power supply. To avoid overloading the SDI-12 power supply, Concurrent measurements can be separated into Concurrent groups. To minimize loading of the SDI-12 power supply select Sequential mode.

Sequential mode uses the SDI-12 'M' (start measurement) commands.

Concurrent mode uses the 'C' (start concurrent measurement) commands. Some SDI-12 devices don't provide concurrent measurement commands - refer to the manufacturer's documentation.

### Concurrent group

This applies to: Measurements, if the Concurrent mode is selected.

Assign measurements to different groups if you need to avoid overloading the SDI-12 power supply.

If required, enter the name of the group that you want to assign the measurement to, for example 'Group 1', 'Group 2'. All measurements in the same Concurrent group are performed in parallel, but separately from measurements in different Concurrent groups.

In any case, Concurrent measurements are performed separately from Sequential measurements.

### Additional

Select **Yes** to use a SDI-12 'additional' measurement or concurrent command and select the Measurement number (below), or **No** to use the default measurement or concurrent command.

Refer to the manufacturer's documentation for details of the measurement that you need.

One example of the use of the Additional property is its use when sensors can present data in different units. For example a soil moisture sensor may be able to output data in units of permittivity  $\epsilon$ , or as volumetric water content in  $m^3.m^{-3}$  or as a percentage.

If this is the case with your sensor then it should say what to do in the sensor's user manual. If it does not say anything then leave this option as **No**.

If these or other additional options are available then select **Yes**, then chose the relevant **Measurement number** as described in the next section.

## **Measurement number**

Applies if: **Additional** is **Yes**

Select the SDI-12 additional measurement number.

This could be used, for example, to express the data in different units, as described above under **Additional**.

## **CRC**

Select **Yes** to request the sensor to provide a CRC (cyclic redundancy checksum) with its measurement results. The logger checks the CRC to confirm it has received the measurement results correctly.

Some SDI-12 devices don't provide a CRC - refer to the manufacturer's documentation.

## **Value position**

Multi-parameter SDI-12 sensors may provide more than one value for each measurement. Refer to the manufacturer's documentation and select the position of the result which you require in the list of values provided by the SDI-12 measurement.

If the SDI-12 measurement requires more than one SDI-12 'send data' command to send a complete set of values, enter the cumulative position of the value which you require. For example, a profiling moisture sensor may provide the values for 10, 20, 30 and 40 cm depths in the first 'send data' command and the 60 and 100 cm values in the 2nd 'send data' command. To obtain the 60cm value, select **Value position** '5'.

## **Measurement duration (s)**

Enter the number of seconds that the SDI-12 measurement takes.

If the information isn't provided in the manufacturer's documentation, enter the measurement command (of type *aM*, *aMn* or *aC*, *aCn*) in the DeltaLINK SDI-12 Transparent mode terminal. The Measurement duration is in digits 2 to 4 of the sensor's response. For example, if the response is '10024' the Measurement duration is '002', i.e. 2 seconds.

## **Send data command.**

Select the SDI-12 'send data' command which provides the required result.

If the sensor provides the result in the first 'send data' command, the Send data command is 'D0'.

In the profiling sensor example above, the appropriate Send data command for the 60 cm or 100 cm values would be 'D1'.

## ***SDI-12 units***

Enter the units of the result provided by the SDI-12 measurement.

You can perform additional calculations on the SDI-12 measurement result by selecting **Calculation properties**.

## ***Power channel***

The GP2's +12V channel is designed to provide up to 500 mA for powering the SDI-12 bus.

If your SDI-12 sensors have a high current consumption it is advisable to power the GP2 from an external power supply - otherwise, the +12V channel may be unable to power the sensors as the internal battery ages and at low temperatures. Peak current consumption can be reduced by selecting Sequential mode (above) for power-hungry SDI-12 measurements, or separating Concurrent mode measurements into Concurrent groups (above).

You can choose to power SDI-12 sensors from any of the other GP2 power channels if they don't require +12V supply. If you don't want to risk power-hungry SDI-12 sensors draining the GP2's battery, you can choose one of the GP2's relay channels to switch an independent external power supply.

Some SDI-12 sensors are designed to be permanently powered and don't respond well to 'power cycling' between measurements. If a manufacturer advises against power switching, select **<none>** and connect the sensor to a permanent power supply.

It is possible to power some sensors from a GP2 **Power** channel and others to a permanent supply and select a Power channel or **<none>** accordingly. However, only one Power channel can be used to power all SDI-12 sensors, so the selected Power channel (if it is not **<none>**) applies to all SDI-12 measurements in a program.

## ***Warmup duration***

Applies if: Power channel or Power channels (above) is not None.

For a SDI-12 sensor, the Warmup duration is the time required by the sensor to power up, initialize and become ready to receive SDI-12 commands. It is applied before issuing any commands to the sensor and is distinct from the Measurement duration (s) - which is the time required by the sensor to complete a measurement after receiving a 'start measurement' command.

SDI-12 sensors in a program may have different Warmup duration; if so, the program allows the longest Warmup duration before issuing a command to any sensor, to ensure all sensors are ready to receive commands.

## ***Further information***

- **SDI-12 Commands** on page 35.
- DeltaLINK online **Help**.



## All commands (apart from “?!”) begin with the sensor address

All SDI-12 commands apart from the “?!” address query start with an address and finish with an exclamation mark ‘!’

### Change Sensor Address “aAb!” command

In this example we change the address from “0” to “P”.

In the DeltaLINK Transparent mode command box type **OAP!** followed by **Enter** or click the **Send** button.

In the output box you see<sup>7</sup> the following:

**OAP!**  
Command ↑ ↑ Reply  
Command terminator

### Sensor Identification “aI!” command

In this example we ask the sensor at address “P” to send its Identity.

In the DeltaLINK Transparent mode command box type **PI!** followed by **Enter** or click the **Send** button.

If you were sending this to a Delta-T SDI-12 PR2 Probe at address P then in the output box, following the PI! command, you would see the following reply:

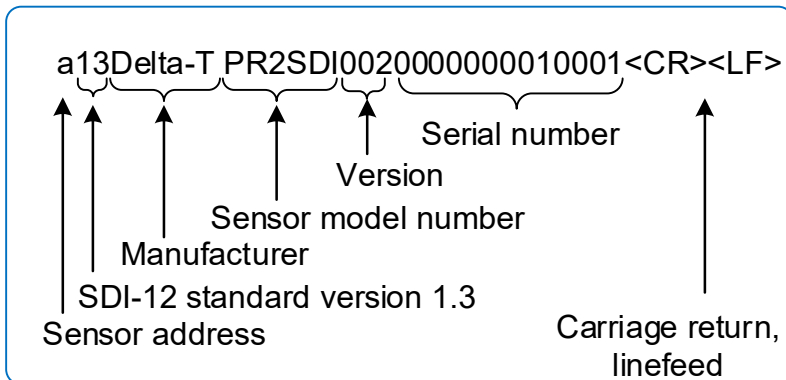

Note: This information is different for each sensor manufacturer

<sup>7</sup> There is also a hidden <Carriage Return> <Line Feed> string at the end of each message, which just acts to display the next reply on a new line.

## “Start Measurement” Command

The “M!” command tells a sensor to start taking measurements.

The sensor responds with the following:

- Measurement duration how long the measurement will take (0 to 999 s)
- Number of values that the measurement will produce (up to 9).

In this example a PR2-SDI sensor is assumed to be at address P

In the DeltaLINK Transparent mode command box type **PM!** followed by **Enter** or click the **Send** button.

The output box displays:...

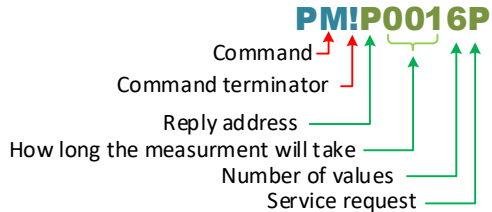

Other measurement commands are also available, to do with the type of measurement. See also Concurrent measurements and CRC (Cyclic Redundancy Checking).

## “Send Data” Command

The “D0” Send Data command is sent to retrieve the results when the sensor is ready. Other commands D1! To D9! are available for retrieving additional results if needed.

In the DeltaLINK Transparent mode Command box type **PD!** followed by **Enter** or click the **Send** button.

Typical replies are shown.

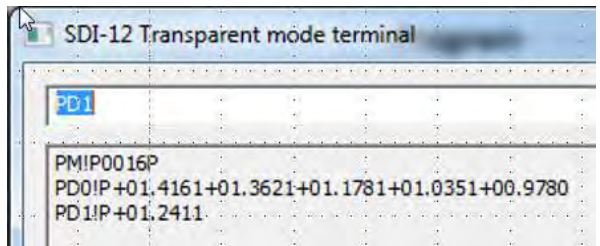

**Figure 7** In this example a **PD0!** command is followed by the **PD1!** Command.

## ***Sequential and Concurrent Measurement Commands***

M! starts a 'sequential' measurement.

- One sensor is active.
- All others in low power quiescent mode

C! starts a 'concurrent' measurement.

- Several sensors can be active and measuring at the same time
- More rapid throughput
- But more loading on SDI-12 power supply
- ... which may be a problem with high current consumption sensors
- Can provide up to 99 values.

## ***More measurement command variants...***

Many sensors also provide additional measurement commands.

i.e. M1! ... M9! and C1! ... C9!

These provide alternative measurement methods.

Each can provide up to 9 (or 99) values.

MC! and CC! commands provide a 'CRC' checksum with measurement results.

This is recommended for optimizing data integrity.

## ***Extended 'X' commands***

M, C, and D commands are 'standard' SDI-12 commands.

X commands may be provided by manufacturers for configuring the sensor.

These are often used to modify behaviour of measurement commands, for example, to change measurement units.

Manufacturers can use X commands to provide a 'Factory reset' command to restore the sensor to a known configuration.

Refer to the manufacturer's data sheets for further information.

# Screw terminal cabling

## Unshielded screw terminal connector kits



**Figure 8** Showing the parts supplied with the screw terminal kits for use with unshielded SDI-12 sensor cables

M12 male 5-way connector kit with screw terminals and plastic shell for attaching SDI-12 sensors which use unshielded SDI-12 sensor cable.

Two cable gland size options are available:

**CON/5W-M-NS-SD** In-line M12 male 5-way connector to screw terminals, with unshielded plastic shell, for connecting SDI-12 sensors fitted with unshielded cable to GP2 logger.  
Accepts cables of **3-6.5 mm diameter**.

**CON/5W-M-NS-LD** In-line M12 male 5-way connector to screw terminals, with unshielded plastic shell, for connecting SDI-12 sensors fitted with unshielded cable to GP2 logger.  
Accepts cables of **4-8 mm diameter**.

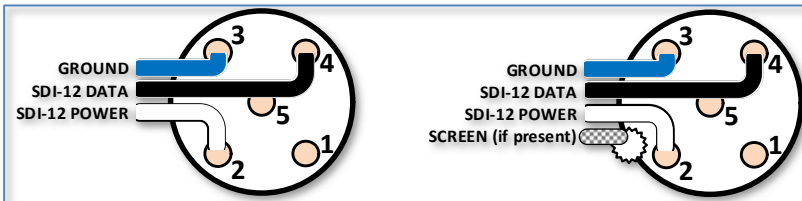

**Figure 9** Wiring schemes used with the screw terminal kits, unshielded on the left, shielded on the right

## Shielded Screw terminal connector.

### CON/5W-M-S-LD

This in-line M12 male 5-way connector to screw terminals, with screened metal shell, for connecting SDI-12 sensors fitted with screened cable to GP2 logger.

Accepts cable 4-9 mm diameter.

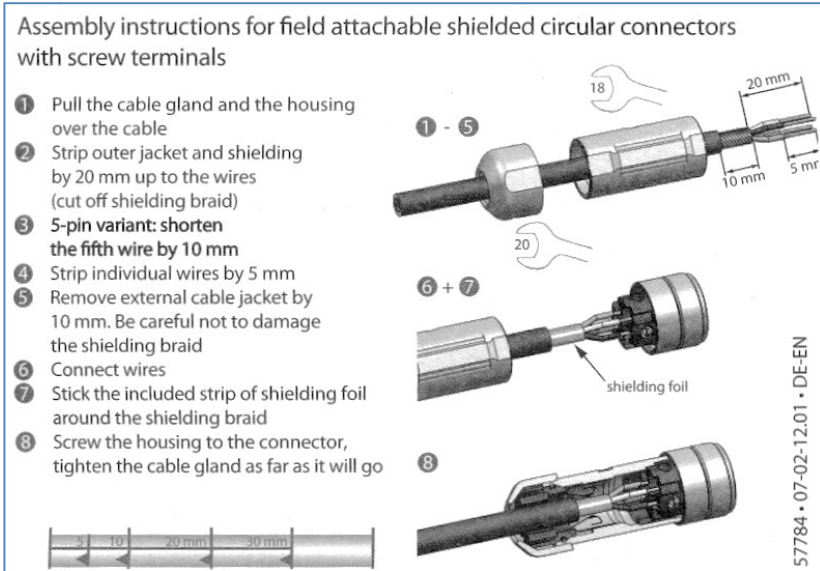

Figure 9 Copy of manufacturer's wiring instructions.

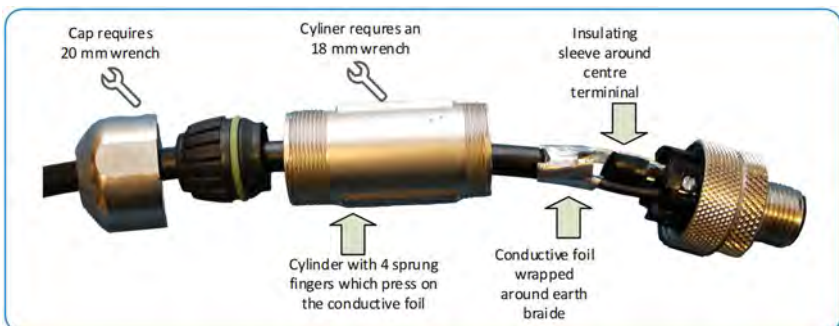

Figure 10 Exploded-view of an example of an SDI-12 sensor cable wired-up using the shielded connector.

# Troubleshooting

## ***Don't get your Networks muddled***

**WARNING:** Do not confuse the **GP2 Logger to Logger Network Cabling** options with the **SDI12 sensor to sensor network cabling** options on page 15.

## ***Fault Finding SDI-12***

### **No SDI-12 sensors appear to be working on the network.**

If one SDI12 sensor fails it can bring down the whole network.

- 1) Isolate each SDI12 sensor by disconnecting all others from the SDI-12 network.
- 2) Use the Transparent Mode to interrogate the one remaining sensor.
- 3) If it appears to be responding with the correct address and meta-data about itself see if it gives sensible readings.
- 4) If the sensor appears to be working, remove it from the network and connect the next SDI-12 sensor and repeat the above.

### **The isolated single SDI-12 sensor is not responding**

Divide and conquer. Swap with other components that you know are working.

- Check the wiring.
- Check the sensor power supply.
- Toggle the power supply off and on.  
Some third-party sensors are known to lock up (intermittently) unless the power is permanently on.
- Check the polarity of the power supply is correct for the sensor.
- Check the logger is working.

If you can prove to your satisfaction the rest of the system is working OK, then the sensor must be faulty or incorrectly connected or incorrectly configured

### **Sensor unreliable if power cycles on and off.**

The GP2's internal sensor power sources help save battery life by only providing warmup power to sensors when needed.

We have found some third-party manufacturer's sensors (not supplied by us) are not reliable unless powered up continuously.

Please check with the manufacturer whether it requires continuous power and if so, you will need to provide this separately.

# Appendix 1: GP2 Relay Expansion Module

## Contents

This contains:

4 x mounting screws.

4 x stand-off pillars

5 x link wire

1 x GP2 relay expansion PCB

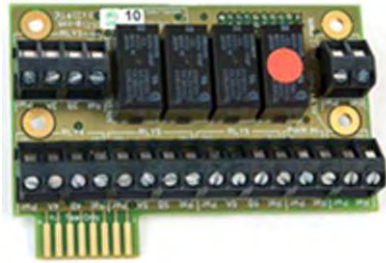

## Overview

The GP2 contains 2 relays, used as switches. This expansion module provides 4 more, bringing the total to 6.

These can only be used with low voltage applications, not mains power.

**DO NOT CONNECT 110V or 240V MAINS POWER TO THE RELAY**

Each relay is protected from overvoltage and overcurrent using a resettable fuse that will activate at 1A. The relays can handle up to 24V AC or 32V DC.

The relay expansion module fits onto the 'EXPANSION BOARD' position on the GP2 PCB (as shown below).

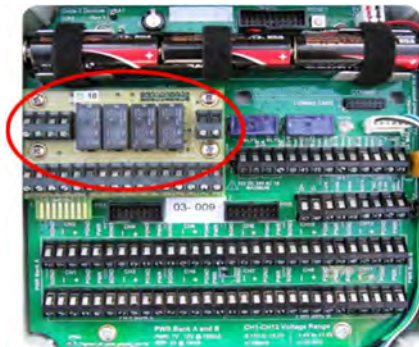
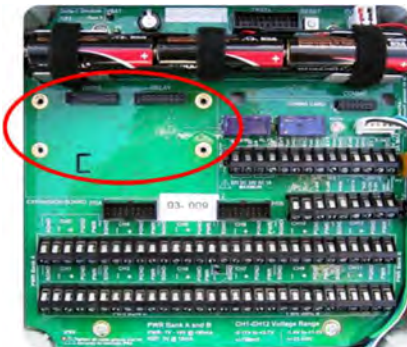

## Fitting Instructions

**Warning: use anti-static procedures when handling the relay expansion module**

1. Screw in the 4 hex stand-off pillars (provided) into the 4 positions on the GP2 PCB
2. Push the relay expansion module onto the GP2 PCB as shown above. The header on the bottom of the module should fit into the 'RELAY' connector on the GP2 PCB and the 4 screw holes should line up with the hex stand-off pillars underneath.
3. Use the 4 screws (provided) to secure the PCB down on to the GP2.

## Relay Layout

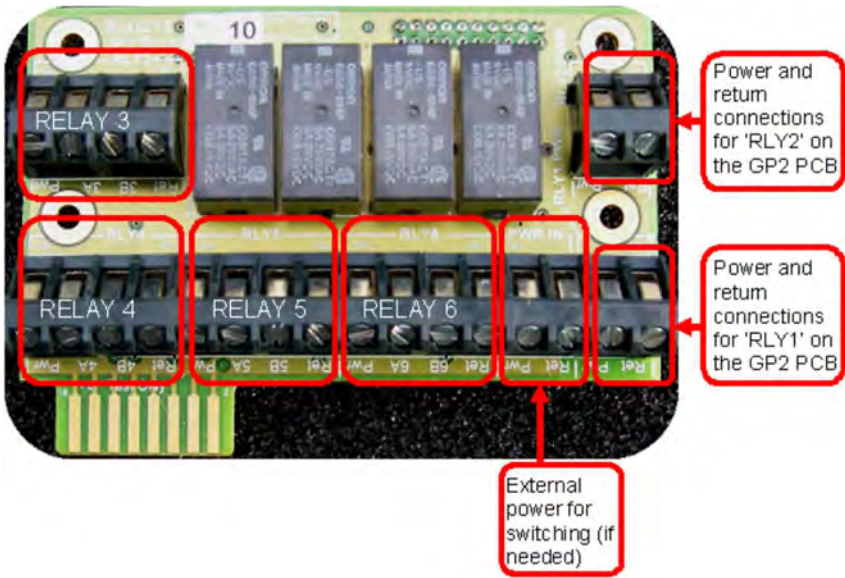

Note: All 'Pwr' and 'Ret' terminals are joined together on the circuit board  
Power should not exceed 1A at 32V DC or 26V AC.

**DO NOT CONNECT 110V or 240V MAINS POWER TO THE RELAY**

## How to Control the Relays

To instruct the relays to switch on or off you need to set up suitable 'control' conditions which meet your requirements. This is done using the DeltaLINK program.

For more information on how to do this, please refer to the DeltaLINK online help. You may also find the video tutorials helpful.

## **Relay Wiring - Option 1:** **Power supply NOT shared by all the relays**

**Using more than one power supply:** To use the relays to switch in various devices where each uses a separate, different power supply then connect the positive wire directly from the selected power supply into the relay of choice. Do not use the 'Pwr' and 'Ret' routing options on the board:

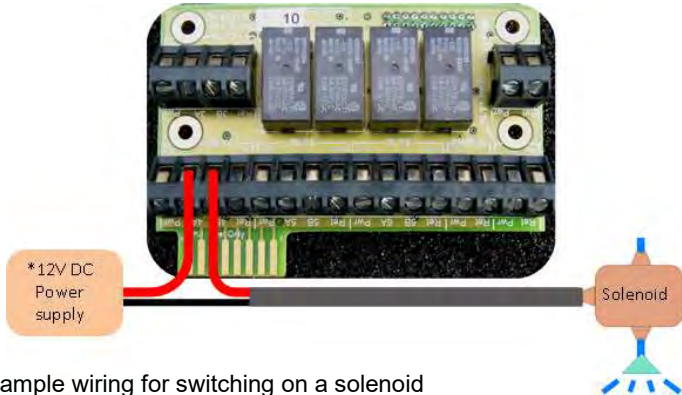

Figure A1: Example wiring for switching on a solenoid valve using the A and B terminals of relay number 4.

### **Relay terminals, applicable to relays 1 - 6**

**Pwr:** Not used.

**A:** Connect to power supply positive (+) output

**B:** Connect to pump positive (+) wire

**Ret:** Not used.

Connect the pump negative (-) wire directly to the power supply negative (-) terminal.

**\*\* DO NOT CONNECT 110V or 240V MAINS POWER TO THE RELAY \*\***

## Relay Wiring – Option 2: Power supply shared by all the relays:

If you want to switch in several devices that all share the same power supply, such as pumps or solenoids, you can use the external power option and route the power through to each relay via the 'Pwr' and 'Ret' terminals:

- **External power in ('PWR IN'):**

**Pwr:** Connect to the +ive terminal on the power supply.

**Ret:** Connect to the –ive terminal on the power supply.

- **Relay terminals, applicable to relays 1 - 6**

**Pwr:** Link to the 'A' terminal next to it, e.g. '4A'

**A:** As above, linked to 'Pwr'

**B:** Connect to pump +ive wire

**Ret:** Connect to pump –ive wire.

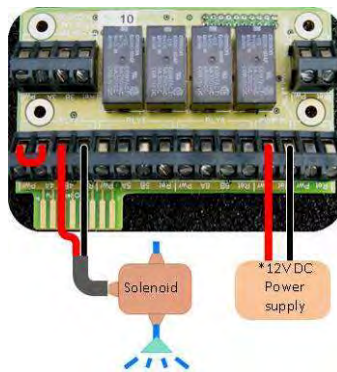

Figure A2: Switching in a solenoid valve using a common power supply through relay number 4

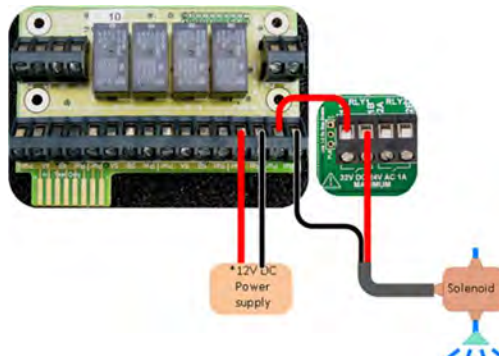

Figure A3: Switching in a solenoid valve using a common power supply through relay number 1 on the main PCB.

\*Warning: The relay only can take up to 1A at 24V AC or 32V DC.

**\*\* DO NOT CONNECT 110V or 240V MAINS POWER TO THE RELAY \*\***

## Appendix 2: GP2 Network Cabling



**Figure A4. A network of 7 GP2 loggers connected to a PC via a total 100m of EXT/5w-xx extension cables and seven M12 5-way “GP2-NTP” T-Piece connectors. This is the maximum number of loggers and maximum cable length supported.**

**Do not use GP2-STP T-pieces for connecting loggers, the STP T-piece is for SDI-12 sensor networks only and won't work with logger networks.**

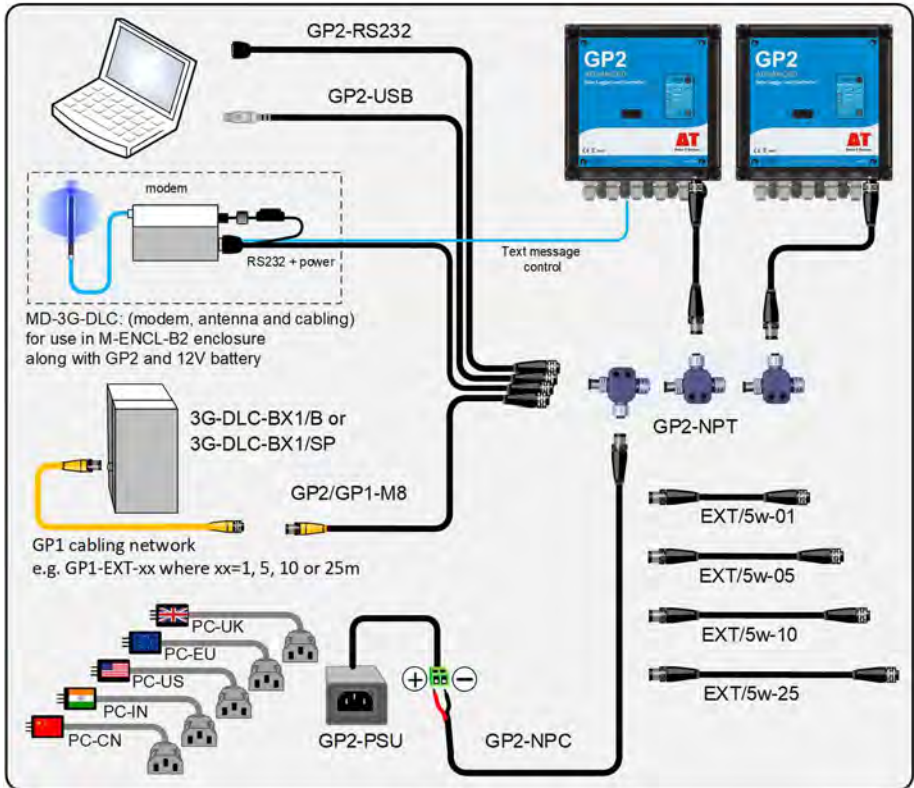

**Figure A5 GP2 Network Cabling options**

## Notes

- A mini USB cable (not shown in Fig A5) - is required in order to configure the modem at the logger end. This is supplied as standard with the Delta-T modem solutions i.e. 3G-DLC-BX1/B and MD-3G-DLC.
- Seven is the maximum number of loggers which can be supported on a combined network of GP1 (and/or DL6) and GP2 loggers.

## WARNINGS

- Only one external power supply should ever be connected to the network. Never connect more than one external battery.
- The GP2 network serial communication and power cable should not exceed 3A or 15V DC.
- Lead acid batteries must have a 2.5A in-line fuse in series with the +ve wire to protect the network cabling.
- Do not charge any external battery (including one in the modem box) via any extension cables.
- These warnings apply to all GP2 and GP1 network cabling systems.

## DeltaLINK System Requirements

You need DeltaLINK version 3.2 or later.

Go to <http://www.delta-t.co.uk/software/deltalink> for the current version.

### Creating a Network Connection

1. Connect your PC to the GP2 network, via the GP2 USB cable or GP2-RS232 cable, or, if using a modem, via the cabling indicated in Figure A5..
2. Start **DeltaLINK**. Select **Connection Details** to display a window listing all (known) logger connections. The first time you do this the list may be empty.
3. In the **Connections** dialog, click **Add...** to pop up the **Connection Properties** dialog. See Figure A6.

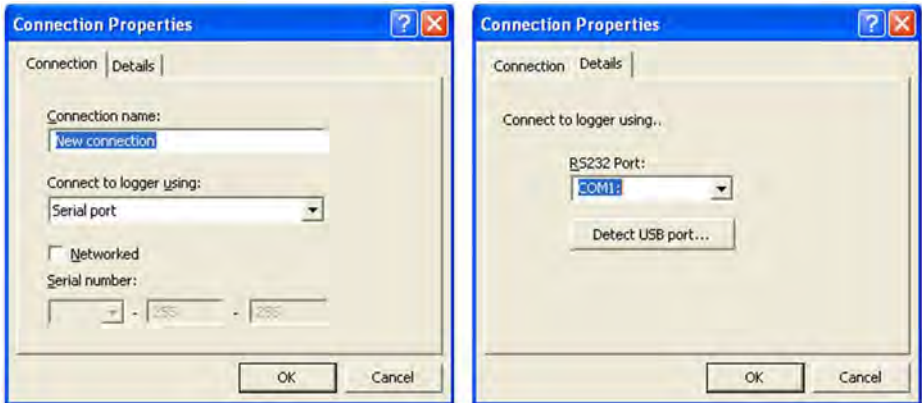
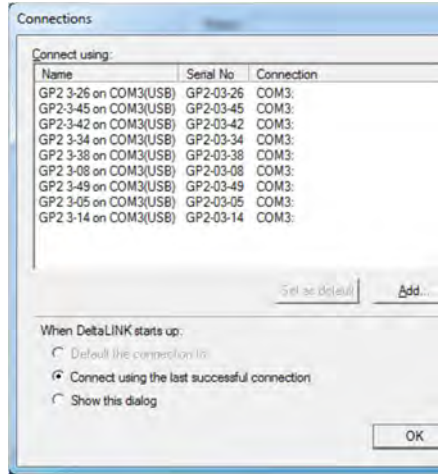

Figure A6 Connection Properties

4. In **Connect to logger using**: select the communication method, e.g. Serial.
5. Select the **Details** tab and enter connection details e.g. COM3.  
See also: **How to Find your COM** Port on page 49.
6. Select the **Connection** tab, tick the **Networked** check box, and enter the serial number of the GP2 that you want to address.
7. Enter a descriptive Connection name, e.g. or "GP2 3-24 on COM3 (USB).
8. Click OK, and in the Connections dialog select the new connection and click OK.
9. DeltaLINK will then open the connection in a new window.
10. Repeat the procedure for each logger on the network, with a unique connection name for each.

**Figure A7 Example showing how DeltaLINK displays connections to GP2 loggers on the network connected to a PC on COM Port 3**



## How to find your USB COM port

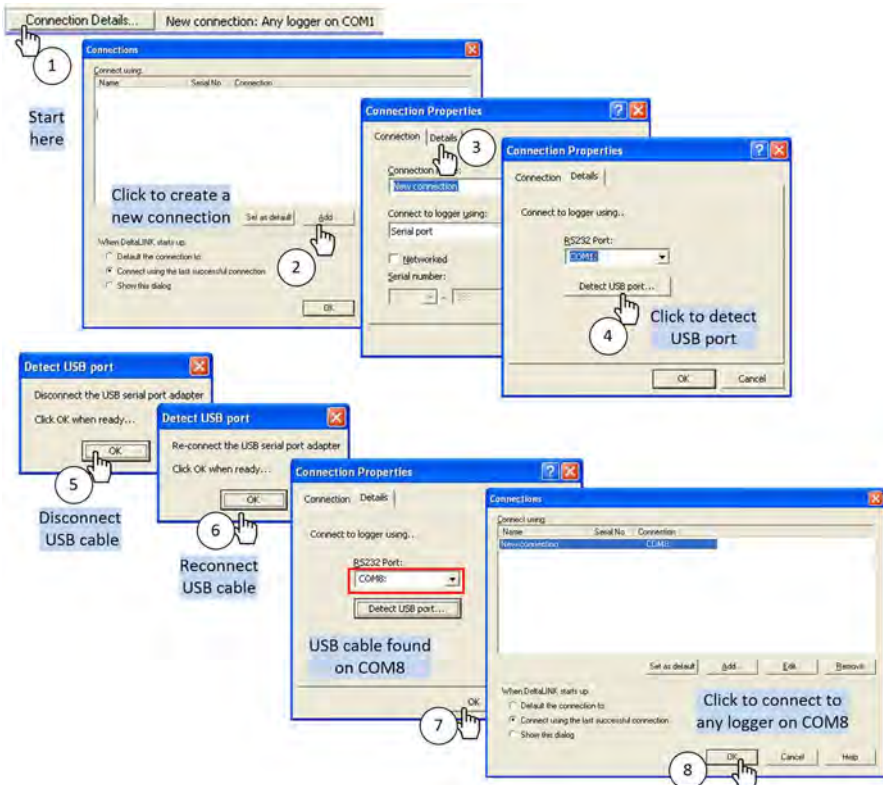

See also: *How do I set up my USB to RS232 converter?*  
at <https://www.delta-t.co.uk/product/gp2/#support>

## Appendix 3: Cable Expansion Lid

Note: The GP2 case has 9 cable glands for 3-6 mm diameter cables. Additional and/or larger cables can be fitted using this expansion lid.

### GP2-G5-LID

This GP2 lid has 5 general purpose cable glands.

Each gland can accept either a cable with an outer diameter of 3 to 10mm diameter, or it can take 2 cables of diameter 3 to 4.5mm - using a gland insert with two holes.



Fit the lid in place using a cross-head cross-head screwdriver (not supplied).

GP2

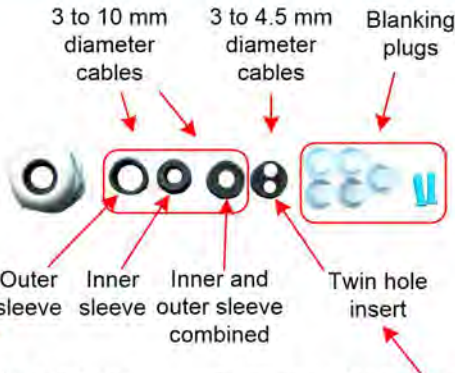

For larger cables separate the inner and outer sleeves and use only the outer sleeve

When using the twin hole insert, ensure both holes are used – if using only one cable, then a blanking plug (or similar) must be put into the other hole. Failure to do this will mean the enclosure is not sealed, and may damage the insert.

See also: **Appendix 7: Make sure the GP2 is properly** on page 54.

# Appendix 4: WS-CAN Canopy



## Parts

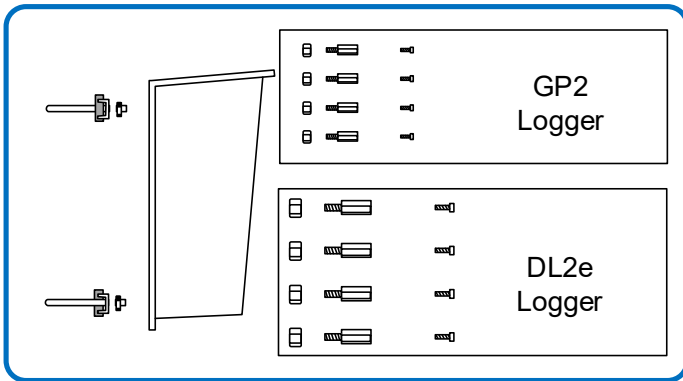

## Assembly

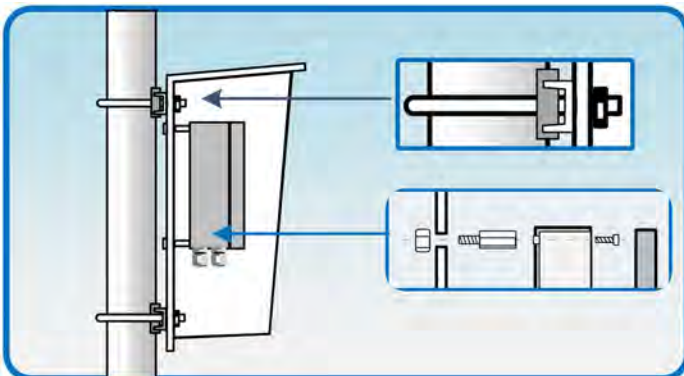

# Appendix 5: DL-MKT Universal Data Logger Mounting Kit

The Universal Mounting Kit is a 2mm thick flat stainless-steel plate with U-bolts suitable for attaching to a 42 mm (1 7/8 inch) diameter vertical pipe or post and with nuts and bolts for GP2, GP1 and DL6 loggers.



## Appendix 6: M-ENCL-B2 Enclosure with Modem Gateway to DeltaLINK Cloud

The enclosure is designed for use with the standard Delta-T M2 2m mast. It is an alternative to the weather station canopy and provides greater weather protection, electrical shielding, and security for GP2 logger and its related accessories.

- Weatherproof to IP54 standard
- Side opening door with twin locks
- Gland plate with 12 cable glands
- Two inch diameter pole mounting brackets (2 off)
- Trunking for tidy cable routing
- Earthed back plate and strap

Detail showing an **M-ENCL-B2** Enclosure with additional options installed:- top left Modem Gateway type **MD-3G-DLC**, bottom left - a solar charger regulator (which along with a 30W solar panel and cabling forms a **SOL4-KIT2**, and bottom right a 12V, 10 Ah battery type **LBAT4**

For further information see:

- M2 Enclosure User Manual
- Modem Gateway User Manual

at <http://www.delta-t.co.uk>.

See also:

- <http://www.delta-t.co.uk/DeltaLINK-Cloud.asp>
- [www.deltalink-cloud.com](http://www.deltalink-cloud.com)



# Appendix 7: Make sure the GP2 is properly sealed.

Make sure the case is not cracked nor damaged in any way.

Check there is no dirt, foreign objects or damage to the rubber lid seal – this could compromise the integrity.

Firmly tighten all 4 lid screws

Make sure the rubber seal in the cable gland looks intact and clean.

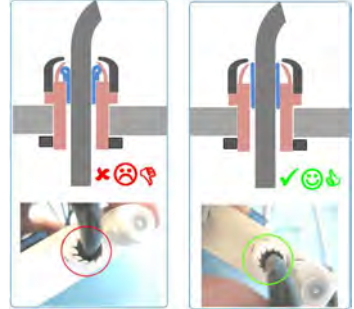

Make sure the rubber seal hasn't peeled back on itself when a cable was inserted.

Ensure unused cable glands have a blanking plug fitted.



Tighten cable glands onto the cable, not onto heat shrink.

Tighten the cable glands as hard as you can by hand or use a torque wrench set to 0.7 nm.

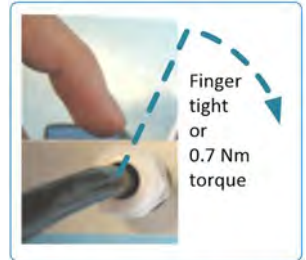

A cable coming out of a GP2 with bare wires exposed, or a break in the insulation, can allow water to enter, so ensure the whole cable is properly sealed.

If possible use sealed connectors and mount the logger vertically with the cable glands facing down.

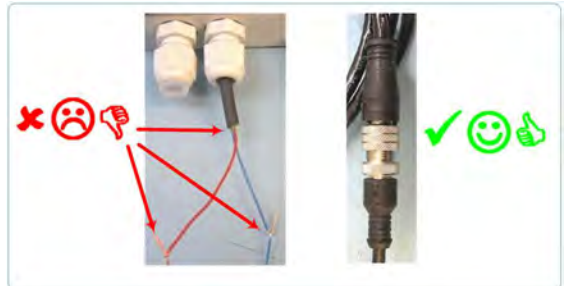

## Appendix 8: Upgrade GP2 Firmware

1. Identify the COM port of the USB adapter used by the GP2:
  - a. Start DeltaLINK 3.
  - b. In **DeltaLINK Logger** view select **Connection Details** (bottom left hand corner).
  - c. **Add** or **Edit** the Connection and select **Connect to logger using: Serial port**.
  - d. Select **Details** and **Detect USB port**.
  - e. Follow the instructions to disconnect and reconnect the USB serial port adapter.<sup>8</sup>
  - f. Note the COM port number.
2. Check your GP2 firmware version, displayed in DeltaLINK.
  - a. If it is not at version 2.10 or later proceed as below to upgrade your firmware.
  - b. Close DeltaLINK.
3. In Windows Start menu click on "All Programs", open the **DeltaLINK 3.2** folder and start **Firmware Upgrade**.
4. Select (or type) the COM port name.
5. Click **Upgrade**

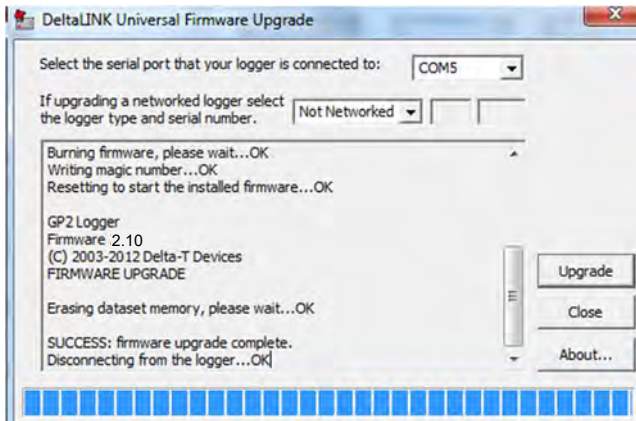
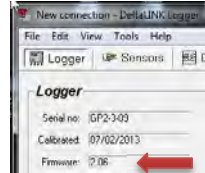

6. Wait while the upgrade is completed, then the Firmware Upgrade

<sup>8</sup> Slower PCs may struggle with this, if so, please use your Device Manager to identify the COM port

# GP2 Specifications

## General Specifications

Program repeat rate	Multiples of 1s
Real time clock	± 1 minutes per month typical, ±5 minutes per month worst case. (-20 to +60 °C)
Communications	RS232 115.2kBaud, USB-RS232 adapter cable supplied
Networking	Up to 7 GP2s on 100 m of network cabling, with optional power distribution over network cabling
Input protection	All terminals protected to ±15VDC, 24VAC, including battery reverse polarity
Regulatory compliance	Surge tested IEC61000-4-5 PASS A ESD tested IEC61000-4-2 PASS A EMC tested IEC61000-4-3 PASS A CE Compliant FCC Compliant
Environmental	Operating: -20 to +60 °C
Enclosure	Fitted with cable glands, IP65
Data storage	4 MBytes FLASH memory. Storage capacity (compressed): 2.5 million values (typical). Autowrap option (i.e. overwrite earliest data when memory full) and/or manual deletion of data without interrupting logging.
Activity indicator	Every 10s, LED signals logging and error status

## Analogue Input Specifications

Analogue input channels	12 differential. Each provided with signal (+), (-) and 0V (SGND), and power (PWR) and power return (PGND) terminals, and individually configurable for differential voltage, 3-wire resistance, bridge, potentiometer, or for a pair of single-ended voltage or 2-wire resistance measurements (up to 24 in total).
Input ranges	4 ranges, -1.4V to 2.7V maximum
Auto-ranging	Optional, adaptive
Sensor source impedance	<11K source resistance <20nF source capacitance
Sensor excitation	20uA current source for resistance and precision 3V for bridge and potentiometric measurements provided at each terminal cluster.
Open circuit detection	Optional, (+) and (-) terminals biased to -5V and +5V respectively for 2 ms via 50K $\Omega$ prior to the measurement
Settling time	Optional, 1 to 200 ms for high value resistance measurements
Reading duration	Per analogue measurement: 6ms built-in settling time + 2ms if open circuit detection enabled + optional settling time + 20ms or 16.67ms depending on mains filter frequency + additional 20 or 16.67ms if 2nd auto-range cycle required Plus, per program execution cycle: 20 ms startup + 2 to 8 self-calibration cycles of 11ms (dependent on mix of required measurements) + 26ms resistance self-calibration if required
Noise rejection	Common mode rejection ratio: >70 dB Common mode range: +3V to -2.5V For Bridge measurements, common mode nulled at +1.5V. Normal mode mains rejection (50/60Hz): 100 - 60dB (0 to 0.1% mains frequency error)
Input leakage	<2nA typical (-20 to +60°C: <12nA)
Input resistance	0.8 to 3.8 G $\Omega$
Stability	0.02% worst case over 1 year Recalibration recommended every 2 years
Cold junction thermistor	Built-in, 0.1°C precision 10K Thermistor + logger contribution as below. Isothermality <0.1°C per 1°C per hour temperature change

## Analogue Accuracy

	Input range	GP2 at 25 ° C	-20 to +60 ° C	Noise*
Voltage differential	-0.17V to 2.7V	0.004% + 87µV	0.036% + 148µV	33 µV
	-1.4V to 1.5V	0.004% + 87µV	0.036% + 148µV	33 µV
	±185mV	0.008% + 17µV	0.067% + 38µV	5.9µV
	±23mV	0.024% + 13µV	0.09% + 31µV	4.3µV
Voltage ** single-ended	-1.7V to 2.7V	0.007% + 86µV	0.043% + 119µV	33 µV
	-1.4V to 1.5V	0.007% + 86µV	0.043% + 119µV	33 µV
	±185mV	0.013% + 11µV	0.076% + 25µV	5.9µV
	±23mV	0.017% + 9 µV	0.084% + 22 µV	4.3µV
Resistance 3-wire	135KΩ	0.045% + 4.15Ω	0.138% + 6.46Ω	1.6 Ω
	9KΩ	0.059% + 0.63Ω	0.184% + 0.93Ω	0.3 Ω
	1KΩ	0.091% + 0.42Ω	0.229% + 0.28Ω	0.2 Ω
Resistance 2-wire	135KΩ	0.045% + 15.4Ω	0.109% + 22.9Ω	1.6 Ω
	9KΩ	0.052% + 11.8Ω	0.155% + 17.4Ω	0.3 Ω
Bridge	±62mV/V***	0.037% + 20µV/V	0.077% + 48µV/V	2 µV/V
	±7.5mV/V	0.053% + 15µV/V	0.100% + 41µV/V	1.5 µV/V
Potentiometer	0 to 1	0.036% + 0.00015	0.057% + 0.00017	36 µV or 0.00002%
Thermistor (3-wire)	10K, -20 to +60°C	0.04°C	0.08°C	<0.01°C
	2K, -20 to +60°C	0.05°C	0.09°C	<0.01°C
Thermocouple**** K type (differential)	±23mV	0.47°C	1°C	<0.3°C

\* RMS noise, included in offset figure

\*\* Single-ended voltage measurements are subject to further offset errors due to current flowing in signal ground.

\*\*\* mV per 1V excitation

\*\*\*\* GP2 contribution to measurement error only, sensor error is additional

## Digital Input Specifications

Counter/frequency/digital state channels	2 x fast, 30 kHz, 30 us debounce 2 x slow, 100 Hz, 5 ms debounce Accepts logic level (low <0.8V, high >2.4V) or open collector or voltage-free switch closure inputs.
SDI-12 sensors	Up to 62 SDI-12 sensors <sup>9</sup> . Limited by 300 measurements, max cable length and GP2 memory.
WET sensor	1 x WET sensor channel (see footnote 4). Water content, bulk/pore conductivity and temperature.

## Relay Outputs

Relay channels	2 plus 4 with optional relay expansion card
Type	Latching, single pole single throw
Rating	24VAC, 32VDC, 1A thermal fuse overload protection
Functions	Alarm, control, scripts, or switching power to sensors

## Other

Dimensions	225 x 185 x 75 mm (Standard lid, no cables)
Weight	1 kg (Standard lid, No packaging, No relay PCB)
Package contents	GP2 logger with lid Desiccant and desiccant storage bag Toolkit- spanner and screwdriver GP2 User Manual
Warranty	2 years

---

<sup>9</sup> The serial input channel can be connected to either one WET sensor or to an SDI-12 sensor network, but not both at the same time.

## Power Supply Specifications

Internal battery	6 x AA alkaline cells
External power	IN: 10 to 15VDC, 2A via screw terminals or network cabling OUT: 2.5A via network cabling
Mains adapter	Accessory, provides 12VDC regulated, 2.5A
Sleep current	< 60uA typical (-20 to +60 °C: 120uA) Plus 30uA for each digital input held low. <1mA (input regulator current) when running from external power supply unit
Wake current	<10 mA, plus any current supplied to sensors
Backup	GP2 draws current from internal battery or external supply, whichever provides the higher voltage, so internal battery serves as backup supply if external power fails. Internal backup capacitor retains program state and maintains the clock for >1 hour for battery change or if both supplies fail.
Low power detection	3.09V to 3.42V shutdown to self-preservation mode 4.1 V analogue readings fail User defined minimum power for analogue measurements powered via PWR Bank A or B (below). Measurements invalidated if requirement not met.

## Sensor Power and Warm-up Specifications

Any of the sources below can be selected for powering sensors. Power is switched when required, either immediately before a measurement or with 1s to 60s warm-up duration in advance.

PWR Bank A	5 to 10.5 V unregulated, 180 mA. Routed to PWR terminals of analogue input channels CH1 to CH6.
PWR Bank B	As PWR Bank A, routed to CH7 to CH12
REF 3V Banks A, B	Calibrated 3V reference for bridge and potentiometer excitation, $\pm 0.2$ mV (-20 to +60: $\pm 0.9$ mV) 18mA. Routed to Bank A and B terminals, so excludes use of PWR on the selected Bank.
WET PWR	5 to 10.5V, 50 mA min, 150mA max unregulated
+5V	5.0VDC $\pm 2\%$ (-20 to +60: $\pm 3\%$ ), 50mA, shared with internal functions
+12V	12 $\pm$ 0.4VDC (-20 to +60: $\pm 0.6$ VDC), 0.5A
Relays RLY 1 to 6	Relay can be configured switch power to sensors from an independent external supply.

# DeltaLINK 3 Software Specifications

DeltaLINK 3 is Windows software for configuring, managing and downloading data from the GP2 data logger

## System requirements

Screen	1024 x 600 or more
Operating system	MS Windows XP SP3 or later

## Features

Compatibility	GP2 (GP1, DL6 data loggers – see footnote <sup>10</sup> )
Logger status	Logger, program, memory and battery status, and error log.
Program settings	Modify selected aspects of program behaviour without interrupting program execution.
On demand measurements	Measurement values charted on demand at any time, for setting up and checking that 'all is well'
Data download	Chart and table views of downloaded data, export as text file. Caching to optimize download times of large datasets
Program editor	Multifunction GP2 program editor displays the logging program, with point and click programming interface (GP2 loggers only).
Online help	Detailed context-sensitive Help and reference.
GP2 simulator	This can simulate a GP2 which is logging Delta-T sensors and operating irrigation valves in a mid-latitude maritime climate. For experimenting with program outcomes. <sup>11</sup>
Command line tool	Downloads and manages logged data and error log. Can run in a Windows scheduled task to automate data download.
Document library	Folder containing rich product documentation and application note resources
Firmware update	Update to most recent firmware version

<sup>10</sup> Software support for DL6 and GP1 loggers uses earlier version of DeltaLINK

<sup>11</sup> The Simulator does not support SDI-12 sensors.

## Multifunction GP2 Program Specifications

Measurements	Analogue, digital, and calculated measurements. Unlimited number (subject to channel availability and program size). Individually configured for input type, calculation method and result limits, or by selection of a sensor type from a sensor library picking list.
Input types	Voltage, resistance, current, bridge, potentiometer, counter, frequency, digital state, WET.
Calculation methods	No calculation, average, min., max., mean, sum, linear scaling, slope and intercept, linearization table, comparator, thermocouple, soil moisture, pore conductivity and custom formulae.
Delta-T sensor library	Delta-T sensor library provides sensor types for all GP2-compatible Delta-T line item sensors, including detailed HTML Sensor configuration notes.
Custom sensor library	User-defined custom sensor library, including configuration notes created with built-in HTML editor.
Recordings	Individual readings, statistics, total, integral, wind (including direction and vector average, gust, wind roses), conditional
Controls	Relay switching controlled by independent Activate and Rest conditions, safety conditions (limit duration of Active and Rest periods), with optional additional recording while Active, and optional pulsing. Conditions expressed as custom formulae and evaluated at defined repeat rates or on a digital event or on a DeltaLINK button click.
Alarms	Relay switching triggered by evaluation of a measurement and comparison against a numeric threshold value(s) or a custom formula. Optional pulsing.
Scripts	Custom scripts, executed at a defined repeat rate, including conditional branches (IF... ELSEIF...ELSE...ENDIF), recording, switching relays and use of variables.
Variables	For use in custom formulae and scripts
Program settings	Variables and critical control parameters optionally configured to be adjusted while the program runs.
Video tutorial	Instructions for building up a sophisticated program in easy stages.

## Script Editor Specifications

Point and click user interface for constructing custom formulae and scripts incorporating the following programming elements:

Statements *	IF... ELSEIF...ELSE...ENDIF, RECORD, ASSIGN
Values	Constants (number, integer, time, duration), variables, measurements, outputs
Operators	Arithmetic: +, -, *, /, % Logical: ==, <>, >=, <, <=, AND, OR
Numeric status	IsNumber, IsNan, IsOverflow, IsUnderflow
Mathematical functions	Minimum, Maximum, Average, Sum, Sin, Cos, Tan, ASin, ACos, Atan, SinH, CosH, Ln, Log10, Exp, Pow, Abs, Atan2
Time and date	NOW, Time, Day of month, Month, Day of Week, Day of Year, Week of Year, Week of Month, Year

\* Statements are applicable only in scripts. Other elements may not be applicable, depending on the context.

## Simulator Specifications

The simulator assists the development of logging and control programs, simulating a temperate maritime climate at a latitude of 51 degrees North, such as that in the UK. Soil water, nutrient and heat fluxes are simulated.

Soil moisture is lost by drainage and by surface evaporation and evapotranspiration - from a spring-sown crop harvested in the autumn.

Water uptake peaks in high summer, nutrient uptake peaking earlier.

Soil water is replenished by rainfall, and by irrigation which is modelled by switching the GP2's relays.

Irrigation can be with fresh water or saline/nutrient solution – these differ in their effect on soil salinity – and can be measured by a simulated flow meter.

The simulator can be speeded up and the same weather pattern can be repeated.

SDI-12 sensors are not currently supported in the simulator.

For full details please see **DeltaLINK 3 Help**.

## Product Care and Maintenance

The battery can be changed quickly without losing program settings or data, but no additional data will be logged while the battery is removed. Change the battery if the voltage indicated on the **Logger** window of **DeltaLINK** is under 5.5V or below the supply voltage needed for sensors.

One 25g bag of **desiccant** protects the logger from condensation. Replace with fresh desiccant annually to ensure continued logger accuracy and reliability. Keep the cover on and cable glands sealed except when connecting sensors or changing the battery.

Logger sealing: See **Appendix 7: Make sure the GP2 is properly** on page 54.

The Service Kit (**GP2-SER**) contains desiccant, a replacement battery holder, spare M8 connector cover cap & lanyard, and spare sealing bungs.

## GP2 Calibration Certificate

To see your current calibration certificate: -

- Connect your PC to your GP2.
- Select Windows Start menu icon , **All Programs, Delta-T Devices, DeltaLINK 3** menu and run **GP2 Calibration Certificate Generator**
- Enter the number of your GP2 COM port connection and, if networked, the GP2 serial number
- Select **Fetch Details from logger**.
- Select **Save** or **Print Certificate** as required.



## Legal and Regulatory Advice

Please read **GP2 Product Usage.pdf** in the **DeltaLINK 3\Document Library** folder. The GP2 is CE compliant, conforming to the essential requirements of EMC directive 2004/108/EC.

For US markets the GP2 is Part 15 FCC compliant.

# Warranty and Service

## Terms and Conditions of Sale

Our Conditions of Sale (ref: COND: 1/07) set out Delta-T's legal obligations on these matters. The following paragraphs summarise Delta T's position, but reference should always be made to the exact terms of our Conditions of Sale, which will prevail over the following explanation.

Delta-T warrants that the goods will be free from defects arising out of the materials used or poor workmanship for a period of two years from the date of delivery.

Delta-T shall be under no liability in respect of any defect arising from fair wear and tear, and the warranty does not cover damage through misuse or inexperienced servicing, or other circumstances beyond their control.

If the buyer experiences problems with the goods they shall notify Delta-T (or Delta-T's local distributor) as soon as they become aware of such problem.

Delta-T may rectify the problem by replacing faulty parts free of charge, or by repairing the goods free of charge at Delta-T's premises in the UK during the warranty period.

If Delta-T requires that goods under warranty be returned to them from overseas for repair, Delta-T shall not be liable for the cost of carriage or for customs clearance in respect of such goods. However, Delta-T requires that such returns are discussed with them in advance and may at their discretion waive these charges.

Delta-T shall not be liable to supply products free of charge or repair any goods where the products or goods in question have been discontinued or have become obsolete, although Delta-T will endeavour to remedy the buyer's problem.

Delta-T shall not be liable to the buyer for any consequential loss, damage or compensation whatsoever (whether caused by the negligence of the Delta-T, their employees or distributors or otherwise) which arise from the supply of the goods and/or services, or their use or resale by the buyer.

Delta-T shall not be liable to the buyer by reason of any delay or failure to perform their obligations in relation to the goods and/or services if the delay or failure was due to any cause beyond the Delta-T's reasonable control.

## ***Service, Repairs and Spares***

Users in countries that have a Delta-T distributor or technical representative should contact them in the first instance.

Spare parts for our own instruments can be supplied and can normally be despatched within a few working days of receiving an order.

Spare parts and accessories for products not manufactured by Delta-T may have to be obtained from our supplier, and a certain amount of additional delay is inevitable.

No goods or equipment should be returned to Delta-T without first obtaining the return authorisation from Delta-T or our distributor.

On receipt of the goods at Delta-T you will be given a reference number. Always refer to this reference number in any subsequent correspondence. The goods will be inspected and you will be informed of the likely cost and delay.

We normally expect to complete repairs within one or two weeks of receiving the equipment. However, if the equipment has to be forwarded to our original supplier for specialist repairs or recalibration, additional delays of a few weeks may be expected. For contact details see below.

### **Technical Support**

Users in countries that have a Delta-T distributor or technical representative should contact them in the first instance.

Technical Support is available on Delta-T products and systems. Your initial enquiry will be acknowledged immediately with a reference number. Make sure to quote the reference number subsequently so that we can easily trace any earlier correspondence.

In your enquiry, always quote instrument serial numbers, software version numbers, and the approximate date and source of purchase where these are relevant.

## ***Contact Details:***

Tech Support Team

Delta-T Devices Ltd

130 Low Road, Burwell, Cambridge CB25 0EJ, UK

e-mail: [tech.support@delta-t.co.uk](mailto:tech.support@delta-t.co.uk)

web: [www.delta-t.co.uk](http://www.delta-t.co.uk)

Tel: +44 (0)1638 742922

Fax: +44 (0)1638 743155

# Index

- 2K Thermistor**, 12
- 3V precision reference, 5
- Additional, 32
- Address, 20, 32
- analogue, 5, 9
- Analogue Accur, 58
- Analogue Input Specifications, 57
- Apply**, 12
- battery power, 5
- blanking plug, 54
- cable glands, 54
- COM port, 49
- Concurrent, 32
- Connect to GP2, 10
- Connection Details**,, 10
- Connector tightening, 15
- counter channels, 5
- CRC, 33
- DeltaLINK, 10
- DeltaLINK 3 Software Specifications, 61
- DeltaLINK Cloud, 53
- Digital Input Specifications, 59
- DL-MKT**, 4
- DL-MKT Universal Data Logger Mounting Kit, 52
- Event Channels, 9
- Excel, 14
- Expansion Lid, 50
- EXT/5W-xx**, 4
- Firmware Upgrade**, 10
- GP2 Program Specifications, 62
- GP2 Relay Expansion Module, 42
- GP2 Simulator, 12
- GP2-G5-LID**, 4, 50
- GP2-NPC**, 4
- GP2-NTP**, 4
- GP2-RLY**, 4
- GP2-RS232**, 4
- GP2-STP1**, 4
- GP2-USB**, 4
- Help, 11
- Individual reading**, 13
- Info Panel**, 13
- Install, 10
- Legal Notices, 64
- Logged Data, 14
- M2 Lockable Enclosure, 53
- M2-ENCL**, 4
- Maintenance, 64
- Measurement duration, 33
- Measurement** list, 13
- Measurement number, 33
- measurements
  - mathematical, virtual, 5
- Mode, 32
- Modem Gateway, 53
- Network Cabling, 46
- Network Cabling options, 47, 48
- Network Power Cable, 4
- power, 4
- Power, 9, 34
- Power Bank, 10
- Power supply NOT shared by all the relays, 44
- Power supply shared by all the relays, 45
- Power Supply Specifications, 60
- Product Care, 64
- Program, 12
- readings
  - maximum number, 5
- Recording**, 13
- recording rates, 5
- recording types
  - statistical, 5
- relay, 5
- Relay Channels, 9
- relay expansion module, 5, 10
- Relay Outputs, 59
- Relay Wiring, 44
- Retrieve, 14
- RS232, 4
- screw terminal connector kit, 39, 40
- Script Editor Specifications, 63
- SDI-12, 15
- SDI-12 Commands, 35
- SDI-12 units, 34
- SDI-12 wiring, 17
- Send Data, 33

sensor  
  reading rate, 5  
Sensor Power and Warm-up  
  Specifications, 60  
**Sensors** tab, 13  
serial, 4  
serial input, 5  
simulator, 6, 13, 63  
Specifications, 56  
Status LED, 9  
Transparent mode, 20  
Troubleshooting, 41

tutorials, 6  
USB, 4  
Value, 33  
variables, 6  
Video Tutorials, 11  
Warmup, 34  
WET sensor, 5, 10  
Wiring, 17  
Wiring Instructions, 11  
**WS-CAN**, 4  
WS-CAN Canopy, 51



Delta-T Devices Ltd  
130 Low Road, Burwell  
Cambridge CB25 0EJ  
UK

Tel: +44 1638 742922  
Fax: +44 1638 743155  
e-mail: [sales@delta-t.co.uk](mailto:sales@delta-t.co.uk)  
[tech.support@delta-t.co.uk](mailto:tech.support@delta-t.co.uk)  
web: [www.delta-t.co.uk](http://www.delta-t.co.uk)