



# Rain Gauge

# User Manual



Document Number: 5150-001 Iss 1 applies to units

## Contents

<b>1. Welcome to the TruMet PW100 User Manual</b>	<b>3</b>
1.1. About this Manual	3
1.2. Overview of Content	3
1.3. Description of Icons	3
1.4. General Notes	3
1.5. Safety Notices	4
1.6. Designated Use	4
1.7. CE and FCC Conformity	4
1.8. Legal Information	4
1.9. User Manual Revision History	5
<b>2. Product Overview</b>	<b>5</b>
2.1. Introduction	5
2.2. Product Overview	6
2.3. Dimensions	8
2.4. Communications	9
2.5. Accessories	10
<b>3. Installation Guidelines</b>	<b>11</b>
3.1. Interference	11
3.2. Site Selection	11
3.3. Leveling	11
3.4. Alignment	12
3.5. Mounting	13
<b>4. Connector and Pin allocation</b>	<b>15</b>
4.1. Connector wiring – pre-moulded cable	15
4.2. Connector Wiring – Manual assembly w/ field-wireable connector	16
<b>5. Use and Maintenance</b>	<b>17</b>
5.1. Introduction	17
5.2. Regular Maintenance	17
5.3. Troubleshooting	18
5.4. Safety and Care	18
5.5. Repair	19
5.6. Warranty	19
5.7. Disposal	19
<b>Appendix A. Technical Specifications</b>	<b>20</b>

### 1. Welcome to the TruMet PW100 User Manual

#### 1.1. About this Manual

This manual provides the information needed to get the best results from your Gill TruMet PW100. Please read this manual before setting up and installing the device.



#### 1.2. Overview of Content

The manual is split into 5 chapters. Each chapter represents an activity in the use of the product.

- **Chapter 1:** Introduction and manual structure.
- **Chapter 2:** Product overview, technology description, and functions.
- **Chapter 3:** Installation information.
- **Chapter 4:** Connector and wiring information.
- **Chapter 5:** Use and maintenance.
- **Appendices:** Technical specifications.

#### 1.3. Description of Icons

The following icons are used in this manual.

Icon	Description
	A note that is important and that should be observed
	Information or a recommendation to ensure best results
	The start of a set of instructions

#### 1.4. General Notes

Before the sensor is used for the first time it is essential to read and understand this manual. Please keep the manual safe for future reference.

- Care should be taken with the sensor at all times.
- Maintenance should be limited to the procedures described in this manual.
- No attempt should be made to open or repair the sealed optical heads; doing so will invalidate the warranty.

### 1.5. Safety Notices



- Read this manual and all safety warnings and instructions before operating and installing TruMet PW100.



- Take care when installing and commissioning the device, and follow all guidelines carefully.



- Take appropriate safety precautions if using live electrical connections. Only operate the device within the voltage range specified.



- This device is not designed to operate in explosive environments.

### 1.6. Designated Use

The TruMet PW100 is designed and intended solely for measuring liquid precipitation in meteorological and environmental monitoring applications. Use of this product for any other purpose may result in personal injury or equipment damage and will void the warranty.

### 1.7. CE and FCC Conformity

This product carries the CE and FCC marks. A copy of the Declaration of Conformity can be downloaded from [gillinstruments.com](http://gillinstruments.com).

This device complies with part 15 of the FCC Rules. Operation is subject to the following two conditions:

1. This device may not cause harmful interference, and
2. This device must accept any interference received, including interference that may cause undesired operation.

### 1.8. Legal Information

Gill Instruments reserves the right to change or revise the device without notice and the obligation to notify any person or organisation of such change or revision.

Gill Instruments reserves the right to change or revise the information supplied in this manual without notice or obligation to notify any person or organisation of such change or revision.

While the information in this manual has been compiled with great care, it may not be deemed an assurance of device characteristics. Gill Instruments shall be liable only to the degree specified in the Terms of Sale.

The reproduction and distribution of the documentation and software supplied with this device and the use of its contents are subject to written authorisation from Gill Instruments.

### 1.9. User Manual Revision History

The following table highlights the revisions of this manual.

Issue	Release Date	Comments
1.0	February 2026	First release

## 2. Product Overview

### 2.1. Introduction

The TruMet PW100 is a high-accuracy, low-maintenance optical rain gauge that uses near infrared light beam technology to measure rainfall. The sensor provides output compatible with traditional tipping bucket rain gauges, making it an ideal replacement or upgrade for existing meteorological installations.

The TruMet PW100 uses an advanced optical measurement system consisting of an emitter and receiver. The emitter generates a near infrared light beam that is detected by a photodiode in the receiver.

As raindrops pass through the light beam, the receiver detects a reduction in light intensity. The measurement system analyses two key parameters:

- **Drop size:** The amount of light intensity reduction corresponds to the size of the drop
- **Drop velocity:** The duration of the light intensity reduction corresponds to the speed of the drop

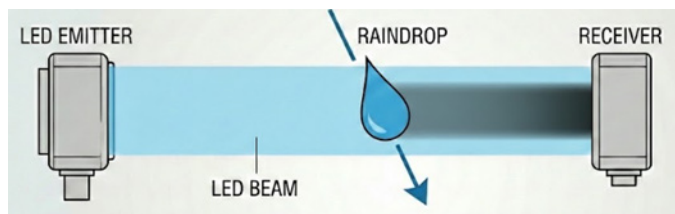

## Rain Gauge

The sensor's algorithms reject light disruptions that do not align with the natural size and speed characteristics of rain, following historical studies (Gunn-Kinzer). By analysing the size of sequential drops, the sensor calculates the total volume of water and outputs pulses exactly like a traditional tipping bucket rain gauge. The amount of rain corresponding to a tip is 0.1mm.

Key features:

- High accuracy measurement ( $\leq 5\%$  accuracy from lab-based tests)
- Solid-state design with no moving parts
- Low maintenance requirements
- Wide intensity range (0 to 200 mm/hr)
- Compatible with existing tipping bucket installations
- IP66 environmental protection
- Wide operating temperature range ( $-35^{\circ}\text{C}$  to  $+70^{\circ}\text{C}$ )
- Able to measure liquid precipitation only (typically from  $0^{\circ}\text{C}$  to  $+70^{\circ}\text{C}$ )

### 2.2. Product Overview

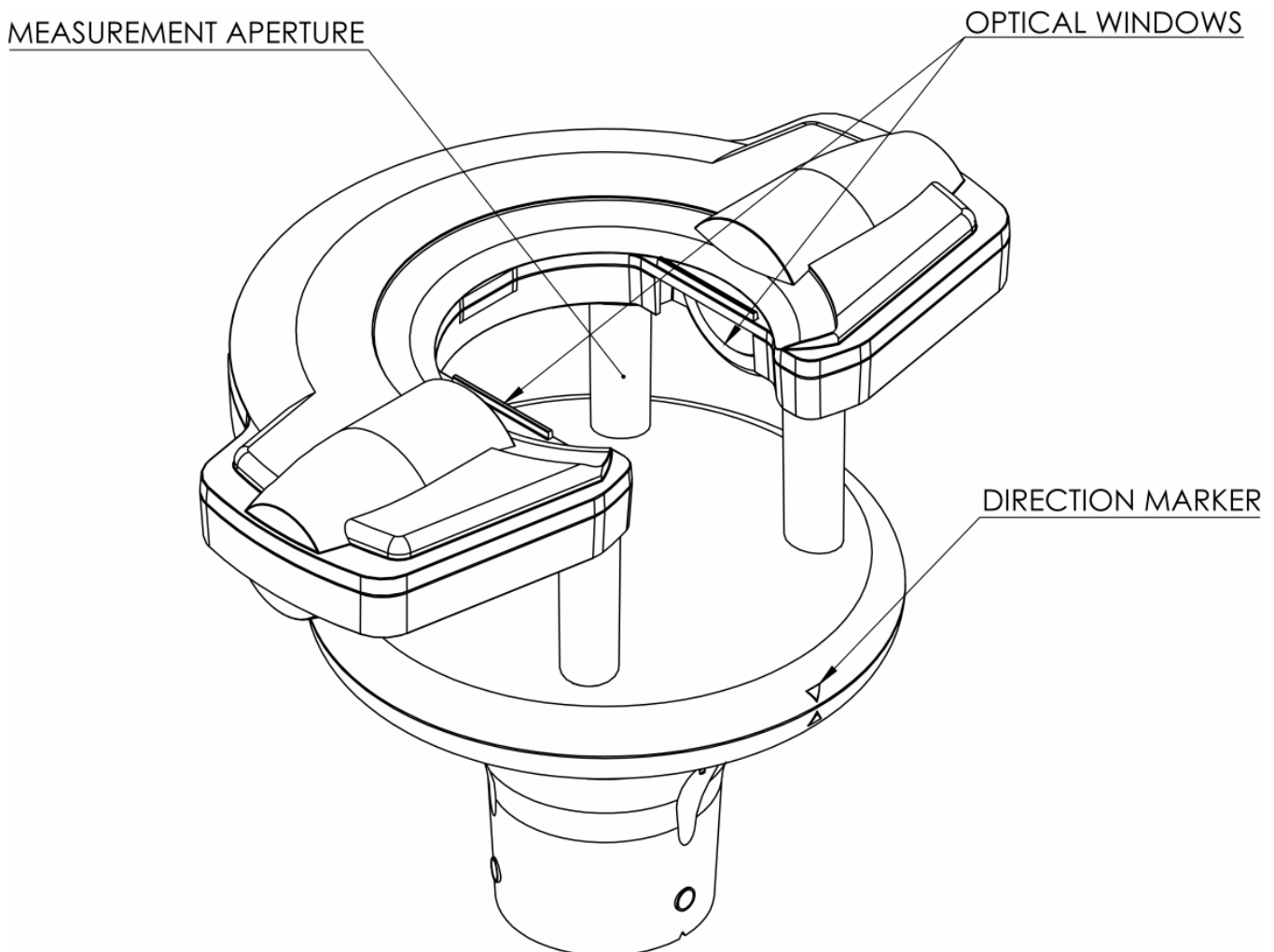

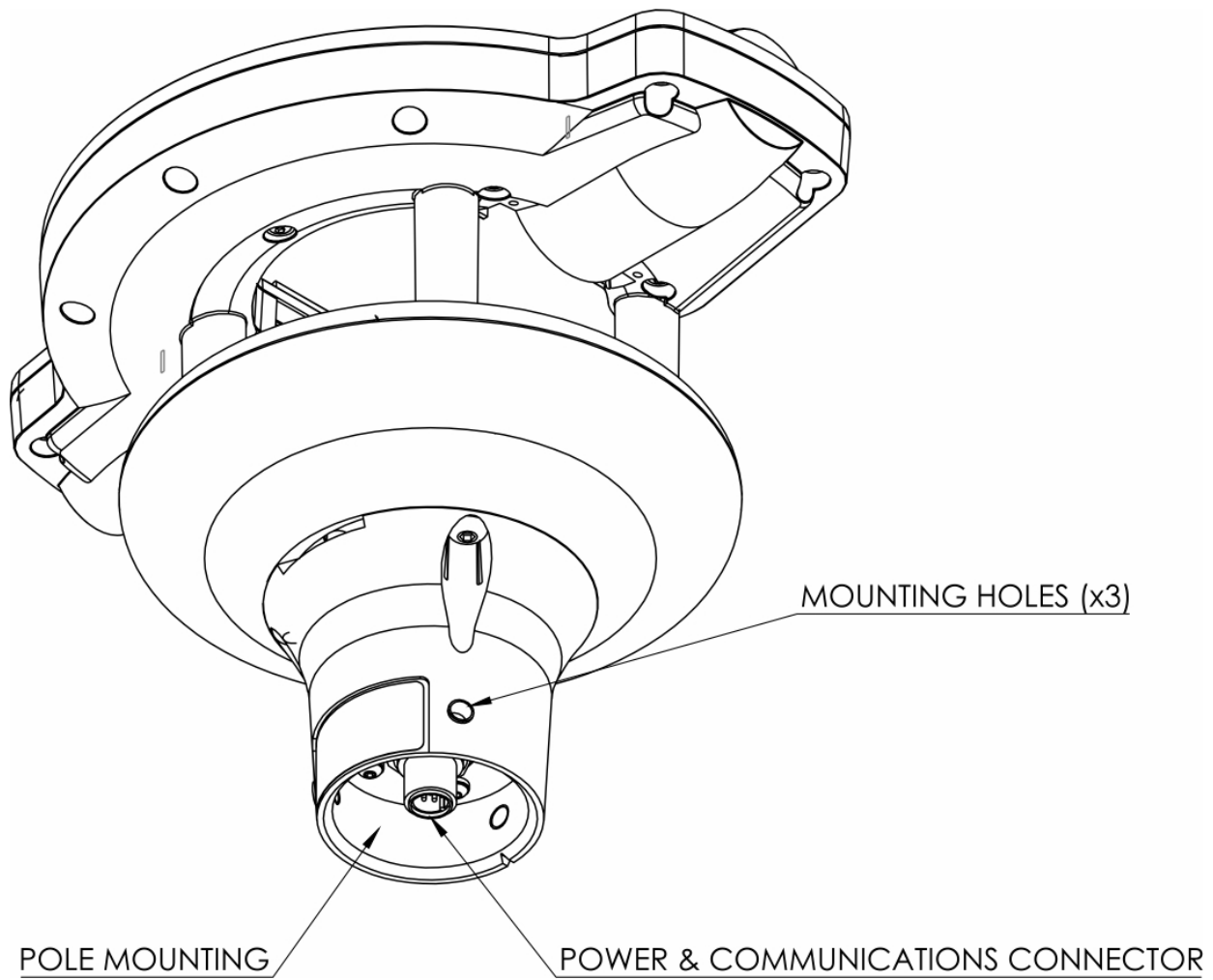

### 2.3. Dimensions

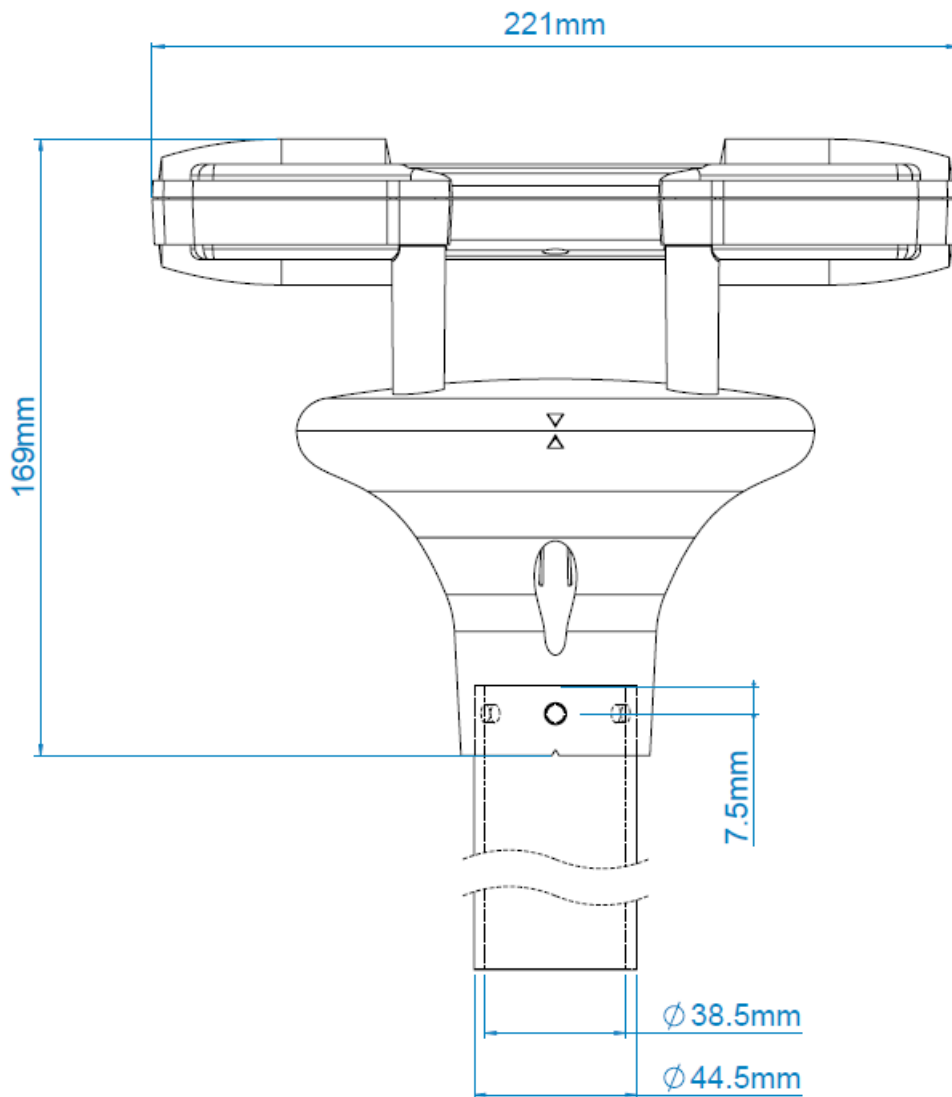

#### Key dimensions:

- Height: 169 mm
- Total length: 221 mm
- Mounting diameter: 44.45 mm / 1.75" pole
- Measurement surface area: 66 x 20 mm
- Weight: 0.67 kg

### 2.4. Communications

The TruMet PW100 provides pulse output that emulates a traditional tipping bucket rain gauge, allowing direct compatibility with existing data logging systems.

#### Tip Output

The sensor outputs a pulse for each 0.1 mm of accumulated precipitation (default tip size). This output is compatible with standard tipping bucket rain gauge inputs on data loggers and weather stations.

The TruMet PW100 mimics a mechanical tipping bucket by closing a switch for 10ms when 0.1mm accumulation threshold is met.

Since the TruMet PW100 is not a mechanical system, no debouncing needs to be accounted for in data logger programming.

#### Power Requirements

- Input voltage: 5-30 VDC
- Average current consumption: ~24 mA @ 12 VDC

#### RS-485 Interface

The TruMet PW100 includes an RS485 serial interface. This interface is not intended for regular use but is available for firmware updates when working with Gill Instruments technical support. Users requiring access to this interface should contact Gill Instruments or their distributor for guidance.

**2.5. Accessories**

A range of accessories is available to support TruMet PW100. A list of accessories is shown below. More information, and the most up to date list of accessories can be found at [gillinstruments.com](http://gillinstruments.com).

Accessories	
Part description	Part number
Connector, M12, 8 way, field wireable	1957-PK-150
Cable, power & communications cable, 2m with fitted M12 connector at sensor end	1416-PK-011
Cable, power & communications cable, 5m with fitted M12 connector at sensor end	1416-PK-012
Cable, power & communications cable, 10m with fitted M12 connector at sensor end	1416-PK-013
Cable, power & communications cable, 20m with fitted M12 connector at sensor end	1416-PK-014
Cable Assembly, MaxiMet to PW100, 20m	5150-PK-039
Support tube, 0.5m with pre-tapped mounting holes	1405-30-056
Pole Mounting Bracket	1771-PK-115

### 3. Installation Guidelines

#### 3.1. Interference

As with any sophisticated electronics, good engineering practice should be followed to ensure correct operation.

Always check the installation to ensure the TruMet PW100 is not affected by other equipment operating locally, which may not conform to current standards, e.g. radio/radar transmitters, boat engines, generators etc.

Do NOT mount the TruMet PW100 in close proximity of high-powered radar or radio transmitters. A site survey may be required if there is any doubt about the strength of external electrical noise.

- Input voltage: 5-30 VDC
- Avoid mounting in the plane of any radar scanner – a vertical separation of at least 2m should be achieved.
- For radio transmitting antennas, the following minimum separations (all round) are suggested:
  - VHF IMM – 1m.
  - MF/HF – 5m.
- Satcom – 5m (avoid likely lines of sight).
- Ensure the product is correctly earthed in accordance with this manual. Please note that there is no earth connection located on the outer body.
- Use cables recommended by Gill, keeping the length below the maximum allowed. Where the cables are cut and re-connected (junction boxes, plugs and sockets) the cable screen integrity must be maintained, to prevent the EMC performance being compromised.
- Earth loops should not be created – earth the system in accordance with wiring diagrams.
- Ensure the power supply operates to the TruMet PW100 specification at all times

#### 3.2. Site Selection

The World Meteorological Organization (WMO) provides guidance for rain gauge siting to ensure measurements are representative and comparable. Gill Instruments recommends following WMO guidance for optimal performance:

- **Exposure:** Install the sensor in an open location with a clear view of the sky
- **Distance from obstructions:** The distance between the sensor and any obstruction (trees, buildings, etc.) should be at least 2 times the height of the obstruction. Ideally, this distance should be 4 times the height of the obstruction
- **Sheltered locations:** Avoid locations sheltered by nearby structures or vegetation that may reduce catch efficiency
- **Ground-level siting:** Ground-level installation is preferred where possible to minimise wind effects on precipitation catch

#### 3.3. Leveling

The TruMet PW100 should be mounted as level as possible for optimal performance. Use a level to check the horizontal plane of the sensor. Adjust the mounting as necessary to achieve a level installation.

### 3.4. Alignment

The TruMet PW 100 includes a direction marker to optimise performance by minimising the risk of the receiver being flooded by direct sunlight.

- i** The direction marker should be aligned according to your hemisphere:
- **Northern Hemisphere:** Point the direction marker EAST
  - **Southern Hemisphere:** Point the direction marker WEST

Use a compass to determine the correct orientation, then rotate the sensor on the mounting pole until the direction marker points in the appropriate direction.

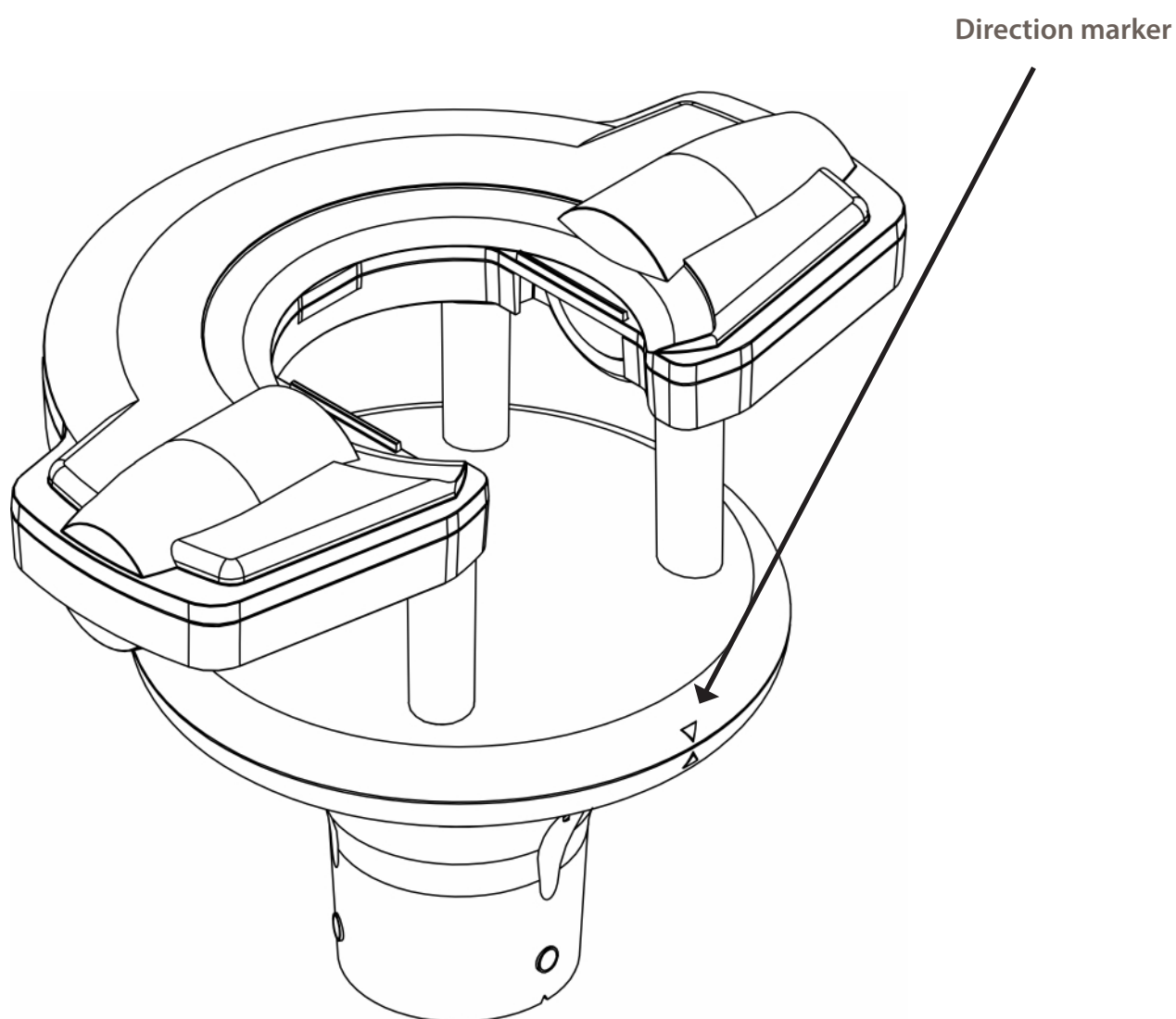

### 3.5. Mounting

Multiple accessories are available for mounting.

#### **Mounting Tube e.g. Gill Part 1405-30-056**

A tube 1.75 inches (44.45mm) outside diameter x 3mm wall thickness is recommended.



It is important that the correct diameter tube is used to prevent damage to the TruMet PW100 lower moulding when tightening the screws.

The support tube requires three 3 equally spaced holes, tapped M5, 7.5mm from the top of the tube. Pass the cable through the tube.

An optional 500mm long x 44.45 mm outer diameter x 3mm thick aluminium mounting tube pre-drilled with equally spaced tapped holes is available from Gill Instruments (Part No. 1405-30-056).



The customer must fit appropriate strain relief to the cable.

Fix the TruMet PW100 to the tube using the 3 stainless steel screws and washers provided. (Maximum mounting screw torque 1.5Nm for Aluminium tubes and 3Nm for Stainless Steel tubes).

For hostile environments, you should select a material suitable for the intended environment – for example, stainless steel 316 for marine use.

For non-hostile environments an aluminium tube can be used.

### Mounting Bracket e.g. Gill Part 1771-PK-115

An optional mounting bracket is available from Gill Instruments Part 1771-PK-115 as per the illustration.

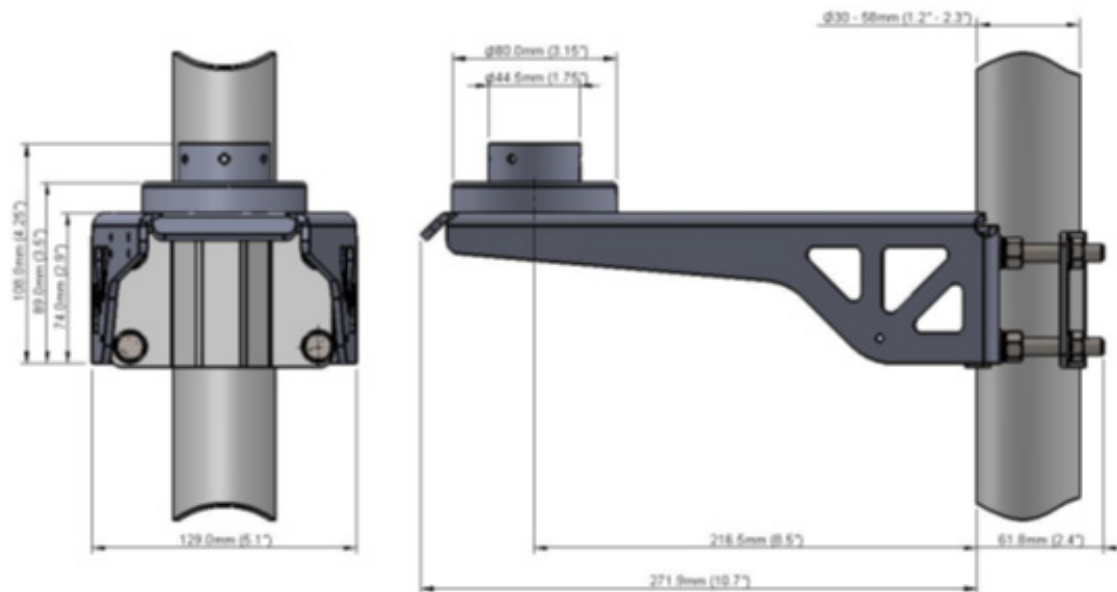

1. Mount the sensor on to the bracket mount.
2. Secure the sensor to its mount using screws and washers supplied in the box.
3. Torque screws to a maximum of 1.5Nm.

The bracket uses a mounting clamp suitable for attaching to a vertical pipe with a diameter of 30-58mm. When mounting the TruMet PW100, consider the position, orientation and alignment of the unit. Mount at the top of a pipe to ensure a clear unobstructed measurement view.



The mounting pipe should first be de-greased and when assembling the bracket clamp assembly, the outer clamp nuts need to be tightened evenly to a torque figure of 3 Nm.

The moving plate part of the clamp needs to be reversed for poles below 38 mm diameter. Screw an Earth cable minimum of 6mm<sup>2</sup> to the bracket chassis using screw and terminal tag fixings supplied (see diagram above).

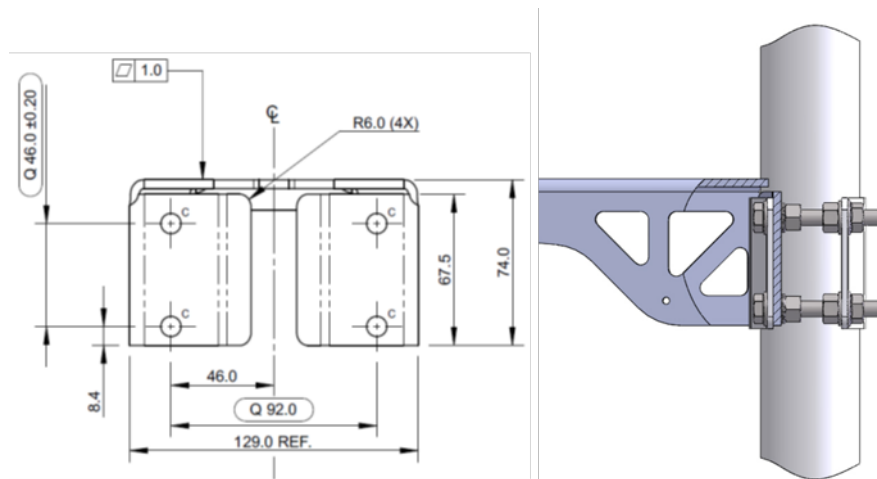

### 4. Connector and Pin allocation

The TruMet PW100 uses an 8 position M12 cable connector. Gill provides pre-moulded cables and field wire-able connectors for various applications.

#### 4.1. Connector wiring – pre-moulded cable

Gill Instruments can provide the recommended halogen-free polyurethane-sheathed shielded 8 x 0.25mm<sup>2</sup> (24AWG) cables with the M12 connector pre-moulded, to connect power and communications to your device.

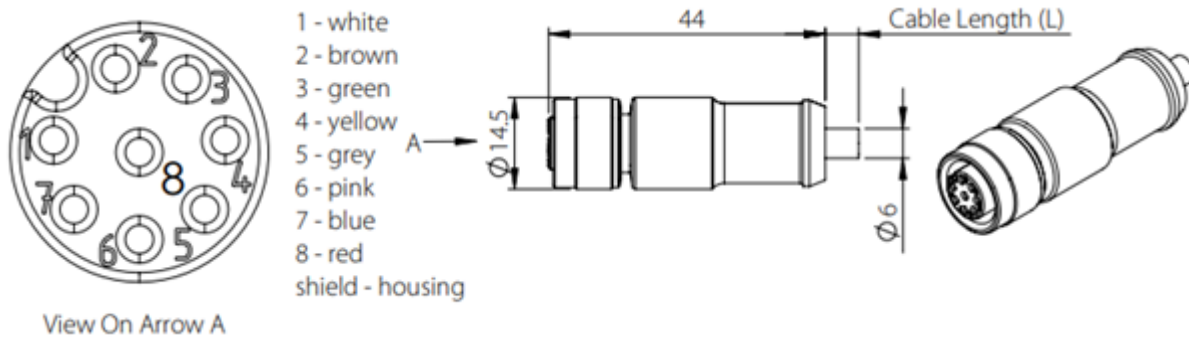

The pre-moulded cable uses the wire colours shown. Use this table to connect to your data-logging equipment

Pin #	Colour	Tip Output (Pulse)	RS-485 (only used for FW updates if required)
1	White	Voltage Supply (V-)	Voltage Supply (V-)
2	Brown	Tip +	-
3	Green	Tip -	-
4	Yellow	-	Data -
5	Grey	-	Data +
6	Pink	Voltage Supply (V+)	Voltage Supply (V+)
7	Blue	-	Signal Ground
8	Red	-	-

### 4.2. Connector Wiring – Manual assembly w/ field-wireable connector

If you are using a field-wireable connector, you will need to provide the required length of cable to the specifications below to connect power and communications to your device. Please contact your distributor or Gill Instruments for cable options.

The field-wireable connector is designed to be straightforward to wire up to a suitable cable.

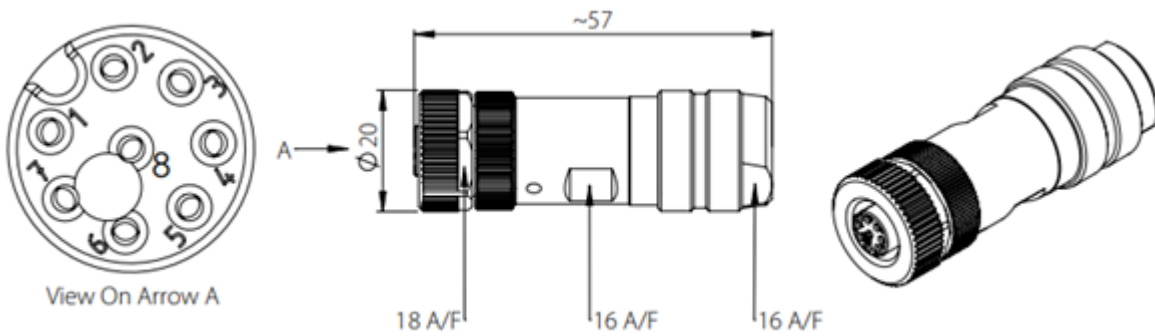

Fold the screen back over the collar with the o-ring. Push the collar into the body. The shield should be gripped between the collar and connector body.

Open up each required terminal with a screwdriver. Strip the amount (indicated below) of each insulated core, and insert it into the correct terminal (note that the diagram does not show the view as seen when tightening the terminal screws). Tighten up the terminal screw until the wire is secure. Then reassemble the connector, tightening the back shell to compress the grommet against the cable.

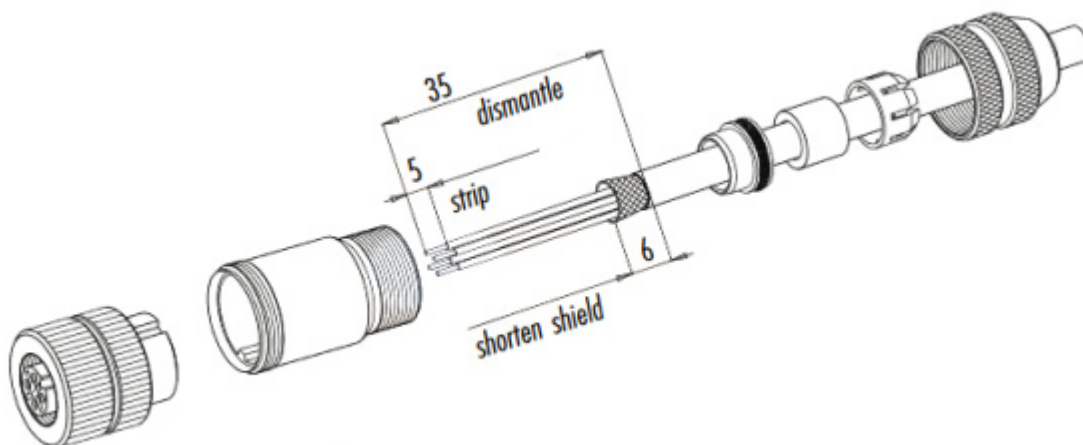

Gill Instruments can supply cable suitable for connecting the product to power and data collection systems

### 5. Use and Maintenance

#### 5.1. Introduction

The TruMet PW100 is designed as a low-maintenance liquid precipitation sensor. The solid-state optical design eliminates moving parts, reducing wear and maintenance requirements compared to traditional tipping bucket rain gauges. However, periodic maintenance is still necessary to ensure optimal performance and accuracy.

#### 5.2. Regular Maintenance

Maintenance requirements will vary depending on the installation environment. Sites with high levels of dust, sand, pollen, or airborne debris may require more frequent cleaning.

#### Cleaning

**i** Clean optical surfaces are essential for accurate measurements.

Under normal conditions, the optical surfaces should be cleaned annually. In dusty or high-pollution environments, more frequent cleaning may be necessary.

To clean the optical surfaces:

- Use a soft, lint-free cloth to gently wipe the optical windows
- If necessary, slightly dampen the cloth with clean water or a non-aggressive optical cleaning solution
- Never use abrasive materials, solvents, or harsh chemicals
- Verify the sensor is still properly aligned

#### General Inspection

During maintenance visits, inspect the following:

- Mounting bracket is secure and sensor has not shifted
- Sensor is still level
- Direction marker alignment is correct
- Cable and connector are in good condition with no signs of damage or corrosion
- No obstructions have grown or been placed near the sensor
- Optical surfaces are clean and free from debris

### 5.3. Troubleshooting

The following table provides guidance for resolving common issues:

Symptom	Solution
No output pulses	<ul style="list-style-type: none"><li>• Check power supply voltage (5-30 VDC)</li><li>• Verify cable connections</li><li>• Check for damaged cable or connector</li><li>• Ensure rainfall is occurring</li></ul>
Reading lower than expected	<ul style="list-style-type: none"><li>• Clean optical surfaces</li><li>• Check sensor is level</li><li>• Verify no obstructions above sensor</li><li>• Check site location meets recommendations</li></ul>

If problems persist after following these troubleshooting steps, contact your distributor or Gill Instruments technical support for assistance.

### 5.4. Safety and Care



Do not attempt to open or disassemble the sealed optical heads. This will void the warranty and may result in permanent damage to the sensor.

- Handle the sensor carefully to avoid damage to the optical windows
- Do not use high-pressure water jets for cleaning
- Store the sensor in its original packaging if not in use

### 5.5. Repair

If the product is damaged, a range of spare parts can be supplied by your local distributor or directly from Gill Instruments.

#### Minor Repairs

Gill Instruments offers a range of accessories such as replacement pole mounts and cables that can be replaced by the user. A list of these parts, and their part numbers, is available on [gillinstruments.com](http://gillinstruments.com)

**i** Opening the sensor will void the warranty.

#### Major Repairs

If the sensor unit is damaged it can be returned for repair via a local distributor or directly to Gill Instruments. The unit should be carefully packed in the original packaging or similar packaging to avoid any further damage. Where possible, a description of the fault, and a list of any fault codes seen, should be included.

Contact details to return a unit to Gill Instruments can be found at [gillinstruments.com](http://gillinstruments.com).

### 5.6. Warranty

If the product experiences issues during the warranty period, please contact Gill Instruments. If necessary the unit can be returned to Gill Instruments together with a copy of the original invoice.

The unit should be carefully packed in the original packaging or similar packaging to avoid any further damage. Where possible, a description of the fault should be included.

Instructions on how to return a unit to Gill Instruments can be found at [gillinstruments.com](http://gillinstruments.com). Any attempt to open the sensor assembly will invalidate the warranty.

### 5.7. Disposal

At the end of its service life, the TruMet PW100 should be disposed of in accordance with local regulations for electronic waste (WEEE).

The sensor contains electronic components that should not be disposed of in general waste. Contact your local waste management authority or Gill Instruments for guidance on proper disposal methods.

All packaging is made from recyclable cardboard to meet REACH guidelines. Either retain the packaging, or dispose of it in a suitable cardboard-recycling facility. The packaging complies with the regulation provisions transposed in France in the articles R543-44 and R543-45 of the Environmental Code (Art. R543-48).

**Appendix A. Technical Specifications**

<b>Precipitation</b>	
Measurement	Optical
Accuracy	≤ 5%
Tip size	0.1 mm
Measurement surface area	66 x 20 mm
Intensity range	0 to 200 mm/hr
Precipitation types	Liquid precipitation
<b>Mechanical</b>	
Construction	UV stabilised thermoplastic
Fittings	Fit to 44.45mm (1.75in) pole or mast
Weight	0.65 kg
Construction type	8-way M12 connector
<b>Output</b>	
Pulse	Tip 0.1mm
<b>Power supply</b>	
Input voltage	5-30VDC
Average current consumption @12VDC	typically ≤ 24 mA
<b>Environmental</b>	
Protection class	IP66
Operating temperature	-35°C to +70°C
Measurement temperature	0°C to + 70°C*
Storage temperature	-4°C to +70°C

\*Unit only accurately measures liquid precipitation