

SapIP Cable Diagrams

CS1W
Cable Set
(2) EXO Skin
OR
(2) Dynagage

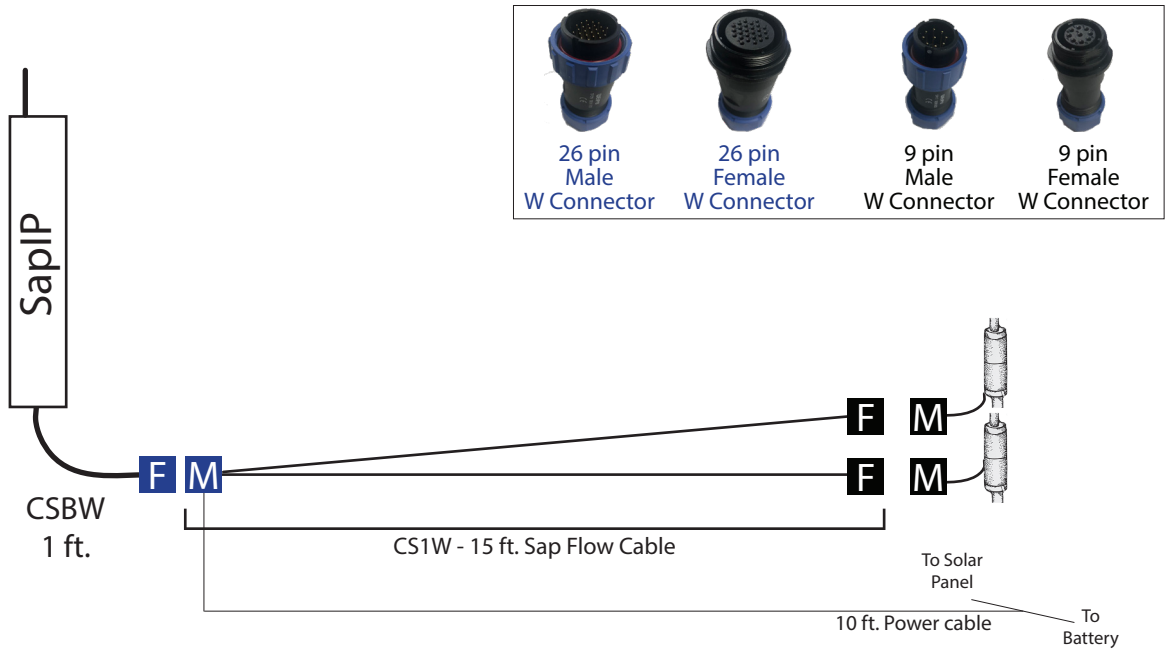

CS2W
Cable Set
(2) EXO Skin
OR
(2) Dynagage
and
rain gage

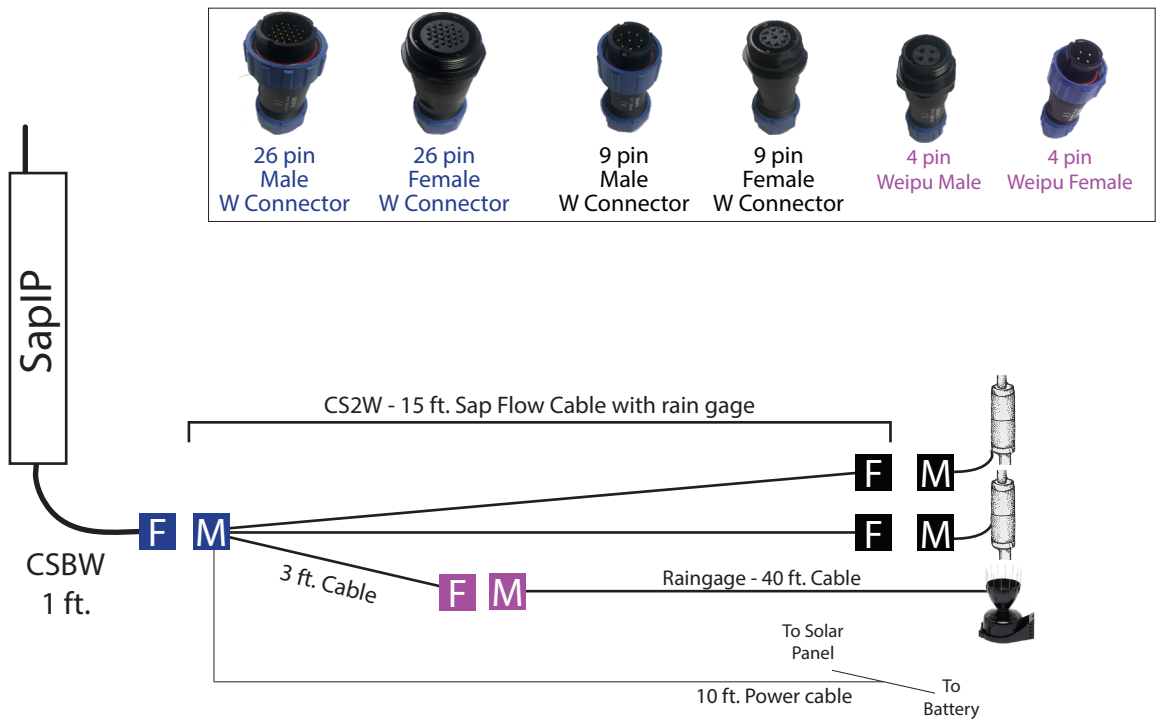

CS3W
Cable Set
(4) SGDC

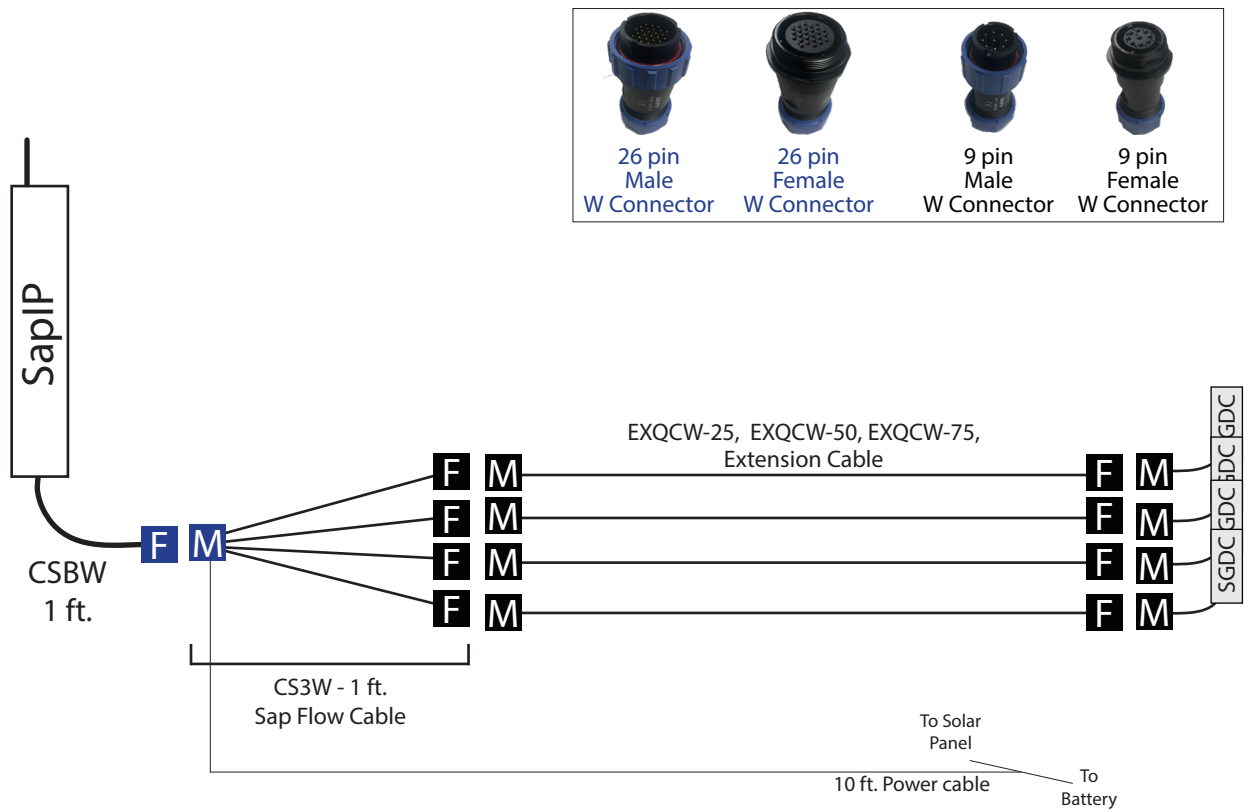

CS4W
Cable Set
(2) EXO Skin
OR
(2) Dynagage

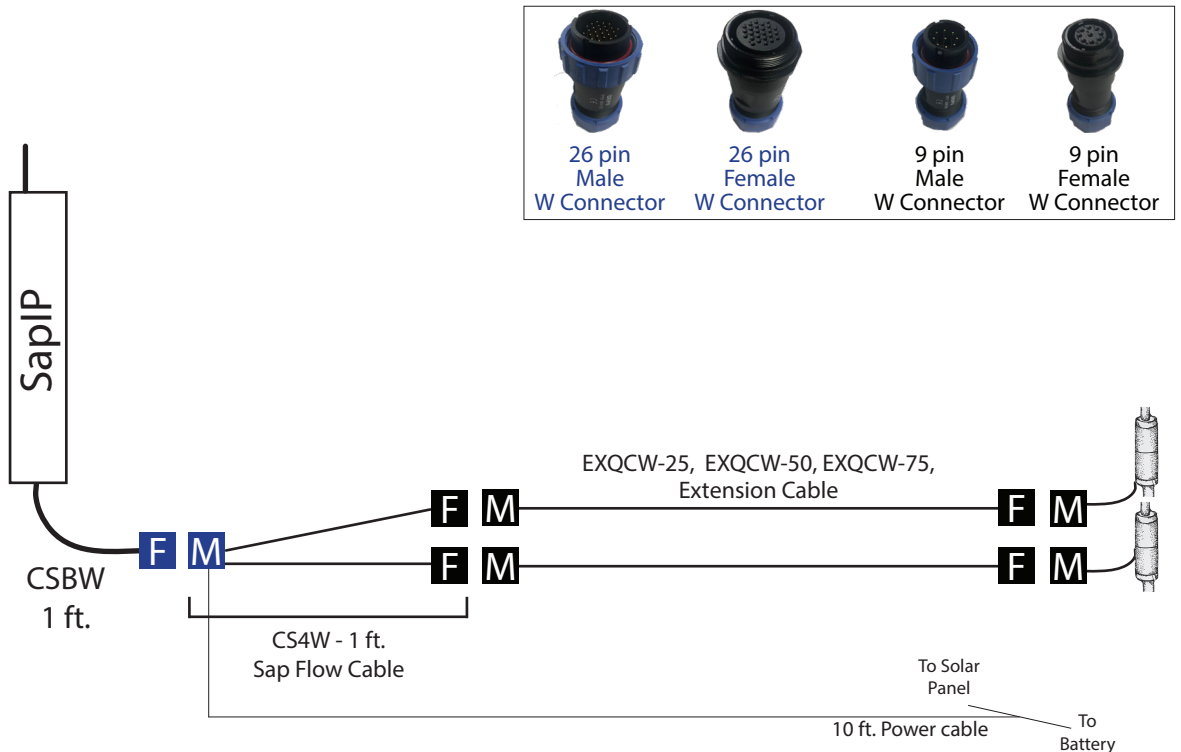



CS5W MicroClimate Cable

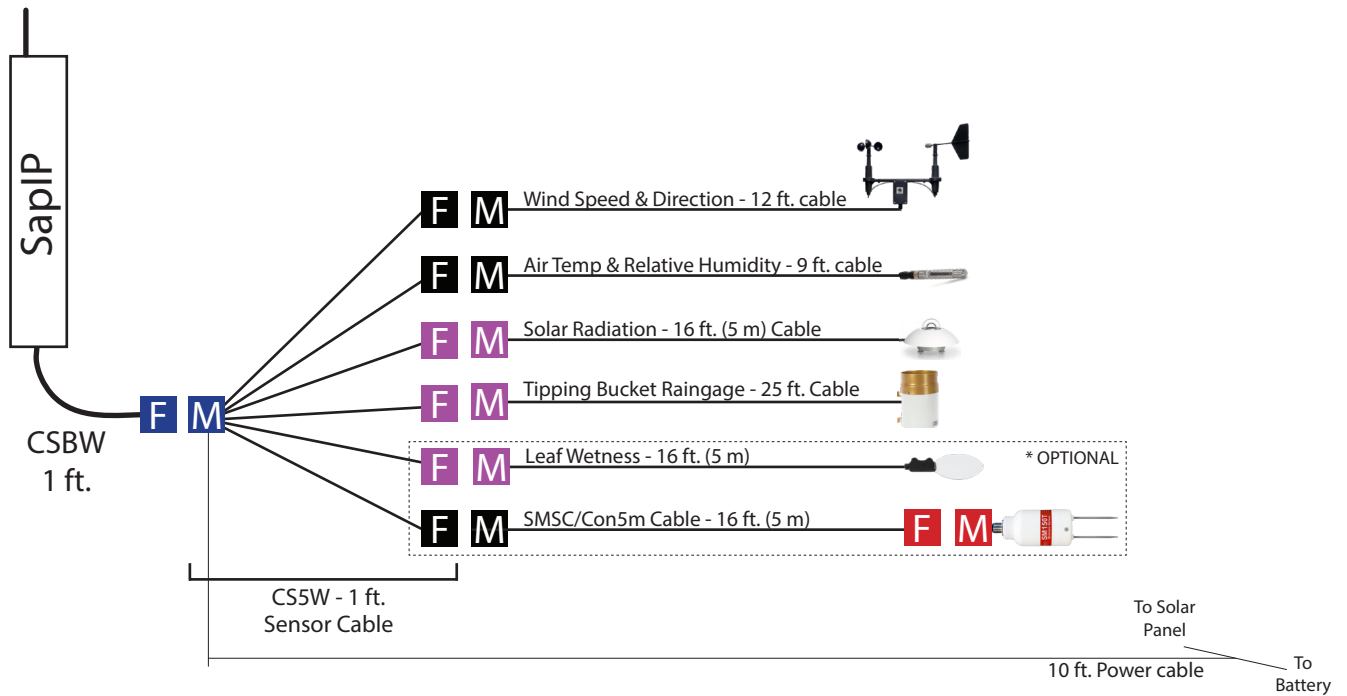

CS6W Cable Set (6) TDP10, 30, or 50*

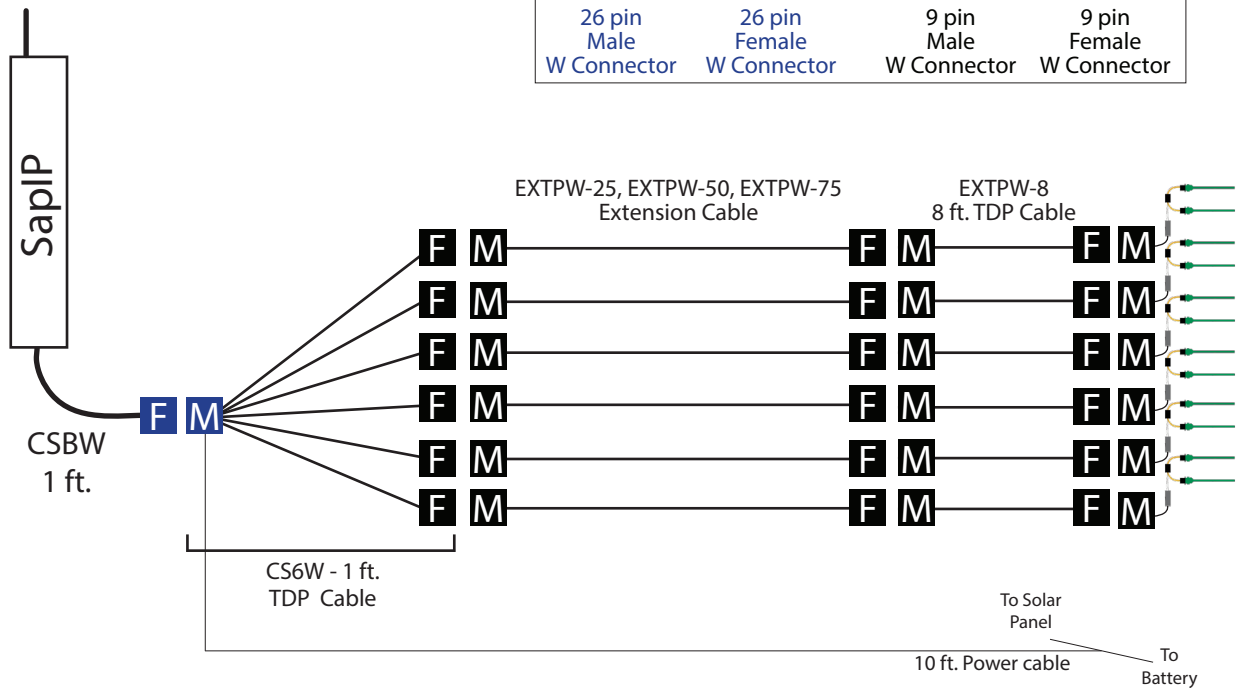

* TDP-80 - (4) Sensors - EXTPW-25D, EXTPW-50D, EXTPW-75D

* TDP-100 - (2) Sensors - EXTPW-25T, EXTPW-50T, EXTPW-75T

CS7W/SM4

Cable Set
(4) SM150T Soil
Moisture
Sensors

(4) SMSC/Con5m included

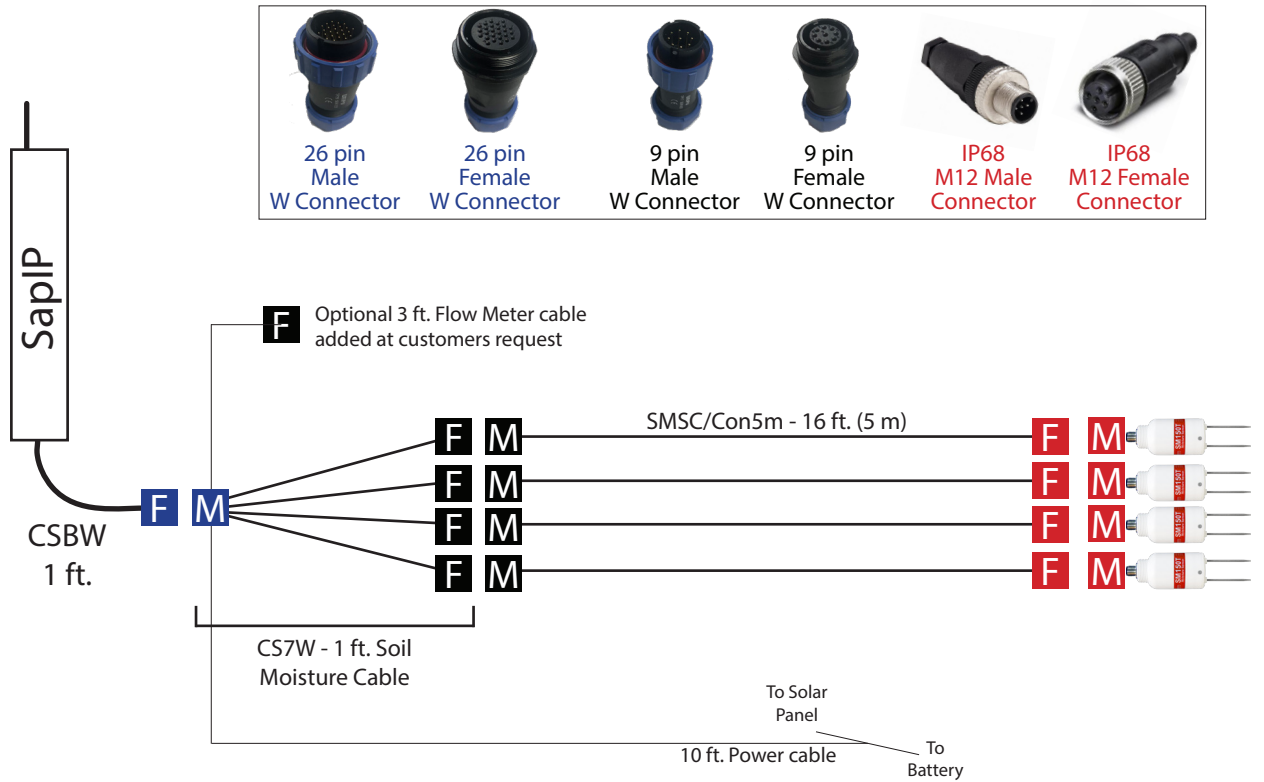

* If extension beyond the 5 meters is needed, use EXTPW-25, EXTPW-50, or EXTPW-75 Extension Cables

CS7W/SM6

Cable Set
(6) SM150T Soil
Moisture
Sensors

(6) SMSC/Con5m included

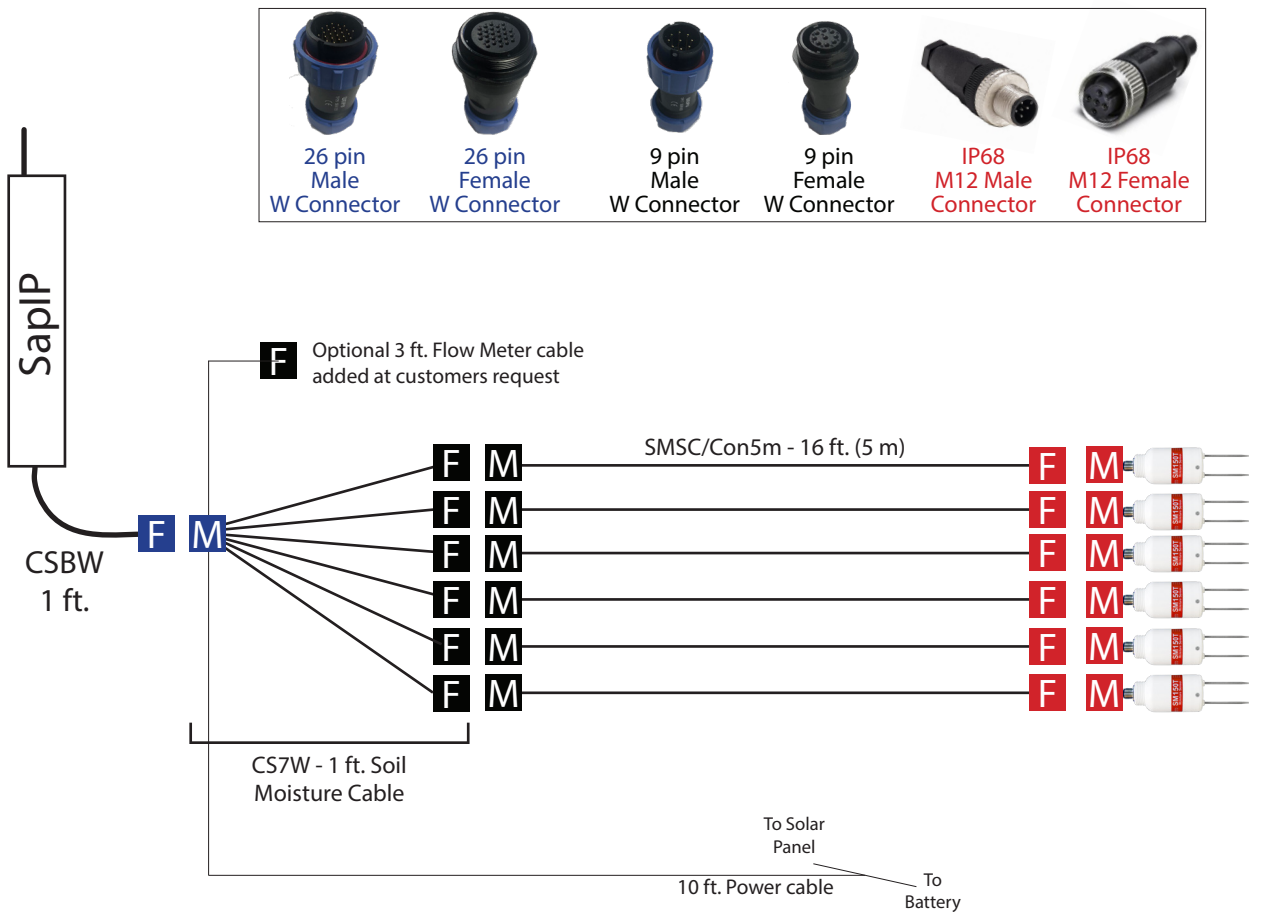

* If extension beyond the 5 meters is needed, use EXTPW-25, EXTPW-50, or EXTPW-75 Extension Cables

CS11W
Cable Set
(3) ML3 Soil
Moisture
Sensors
with soil temp.

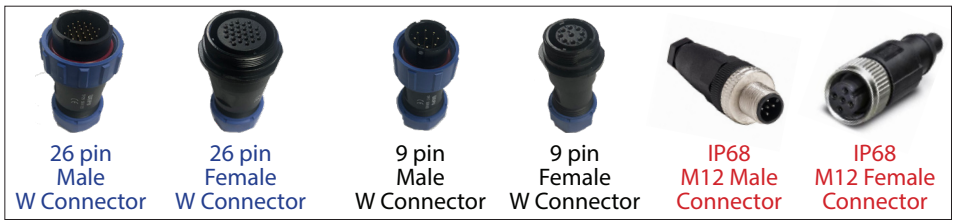
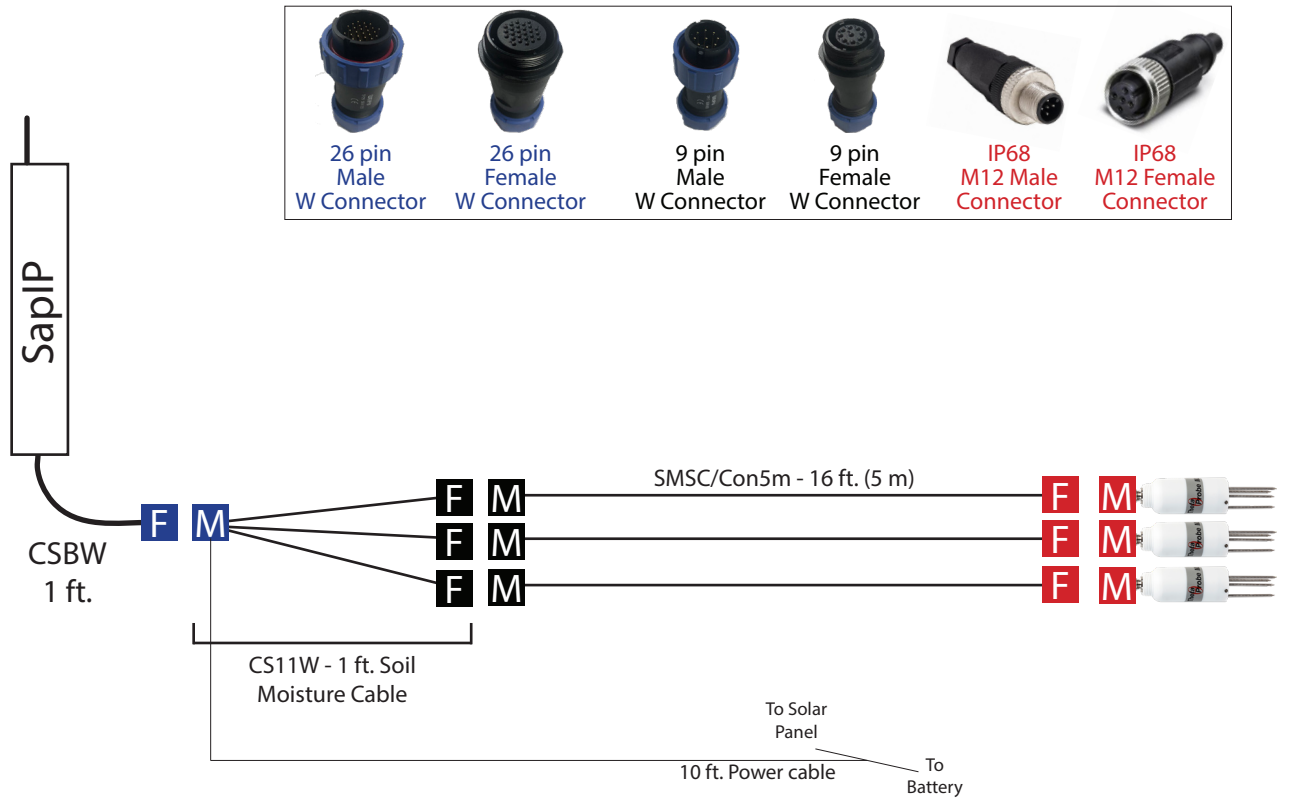

* If extension beyond the 5 meters is needed, use EXTPW-25, EXTPW-50, or EXTPW-75 Extension Cables

CS13W
Cable Set
(6) IRT

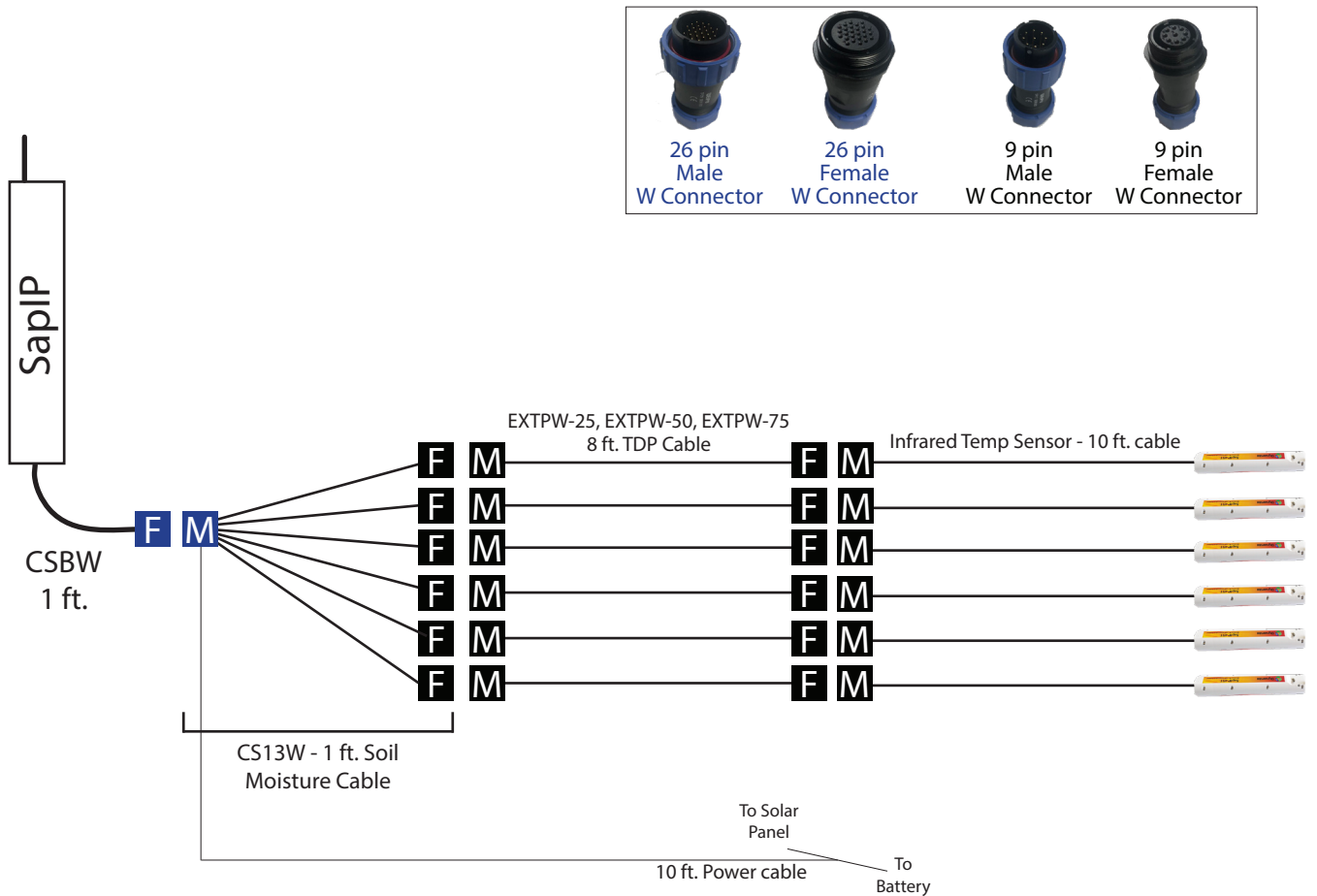



CS15W
Cable Set
(2) IRT
(2) SM150T

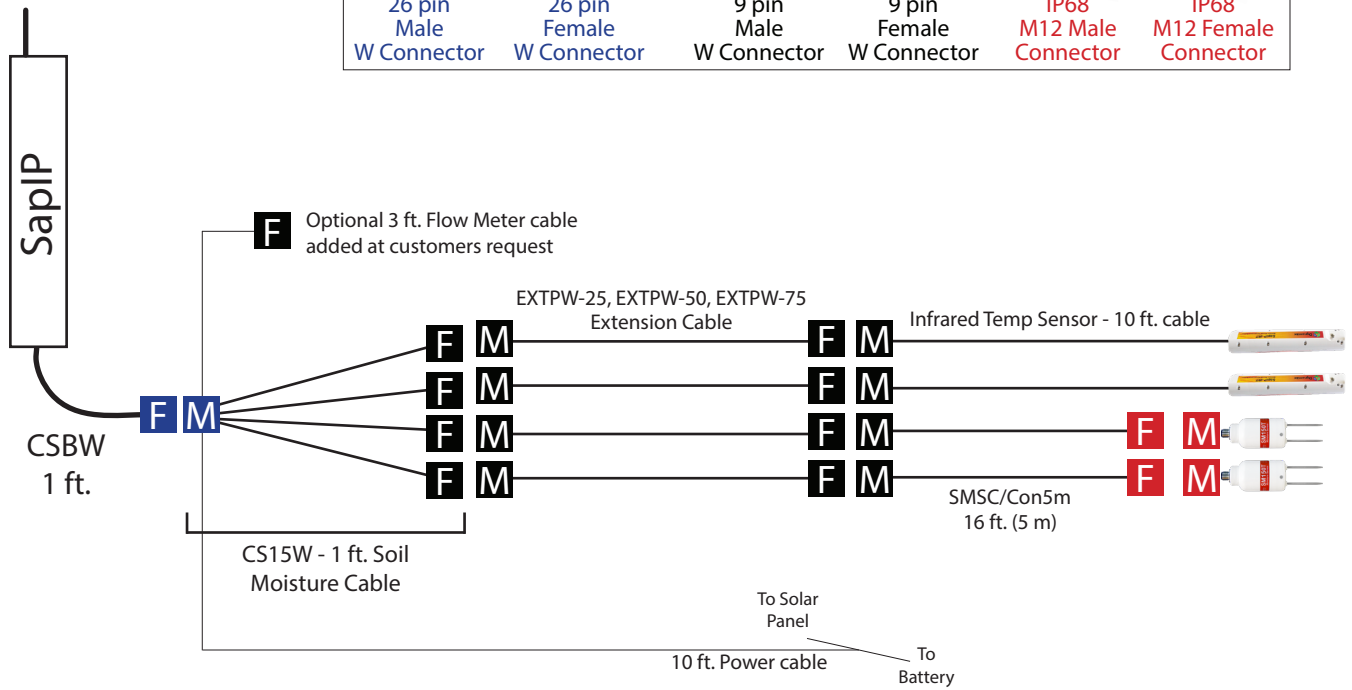

CS16W
Cable Set
(4) SM150T Soil
Moisture
Sensors
with Soil temp

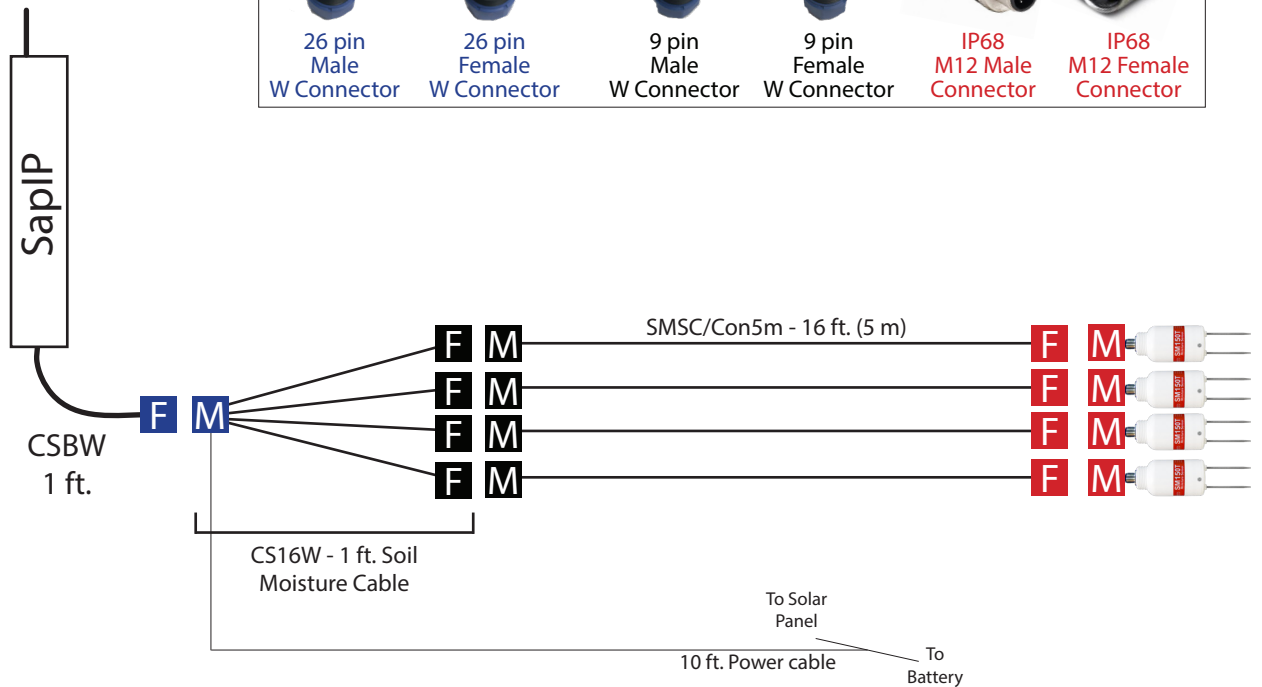

* If extension beyond the 5 meters is needed, use EXTPW-25, EXTPW-50, or EXTPW-75 Extension Cables

CS17W
Cable Set
(2) IRT
DEX
Dendrometer
PRT

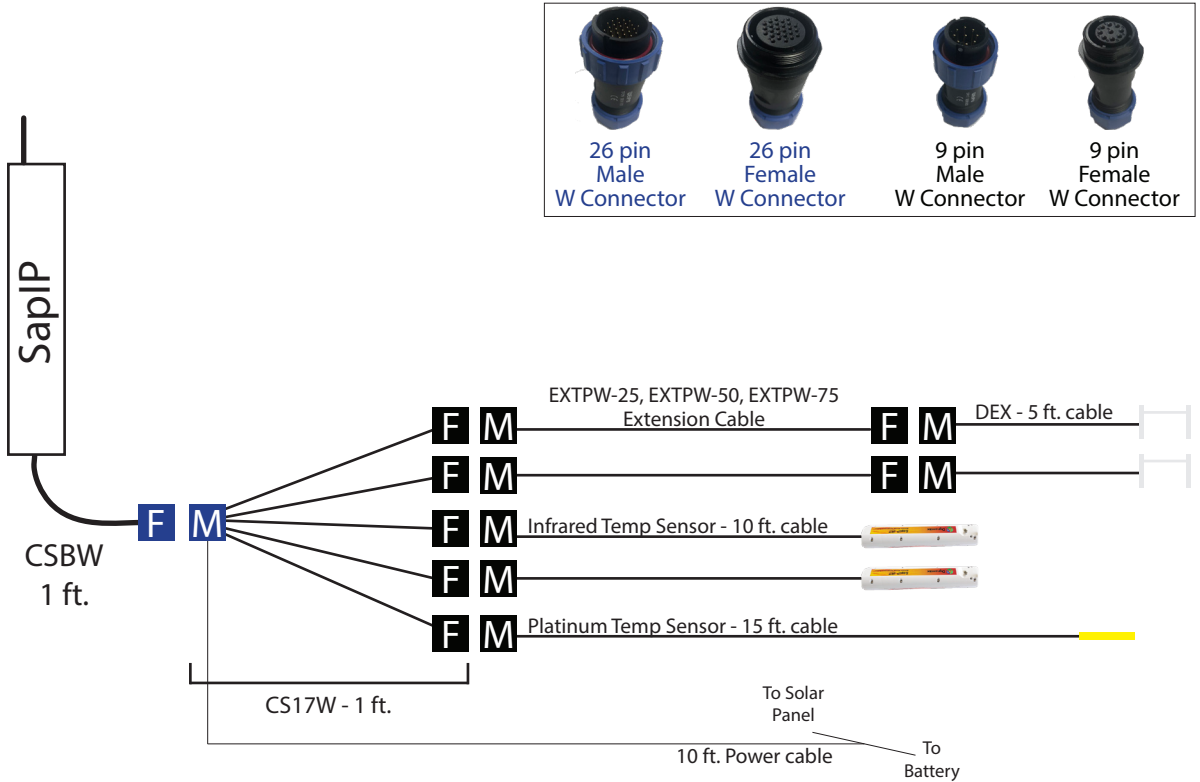

CS18W
Cable Set
Sap Flow
(3) DEX
Dendrometer

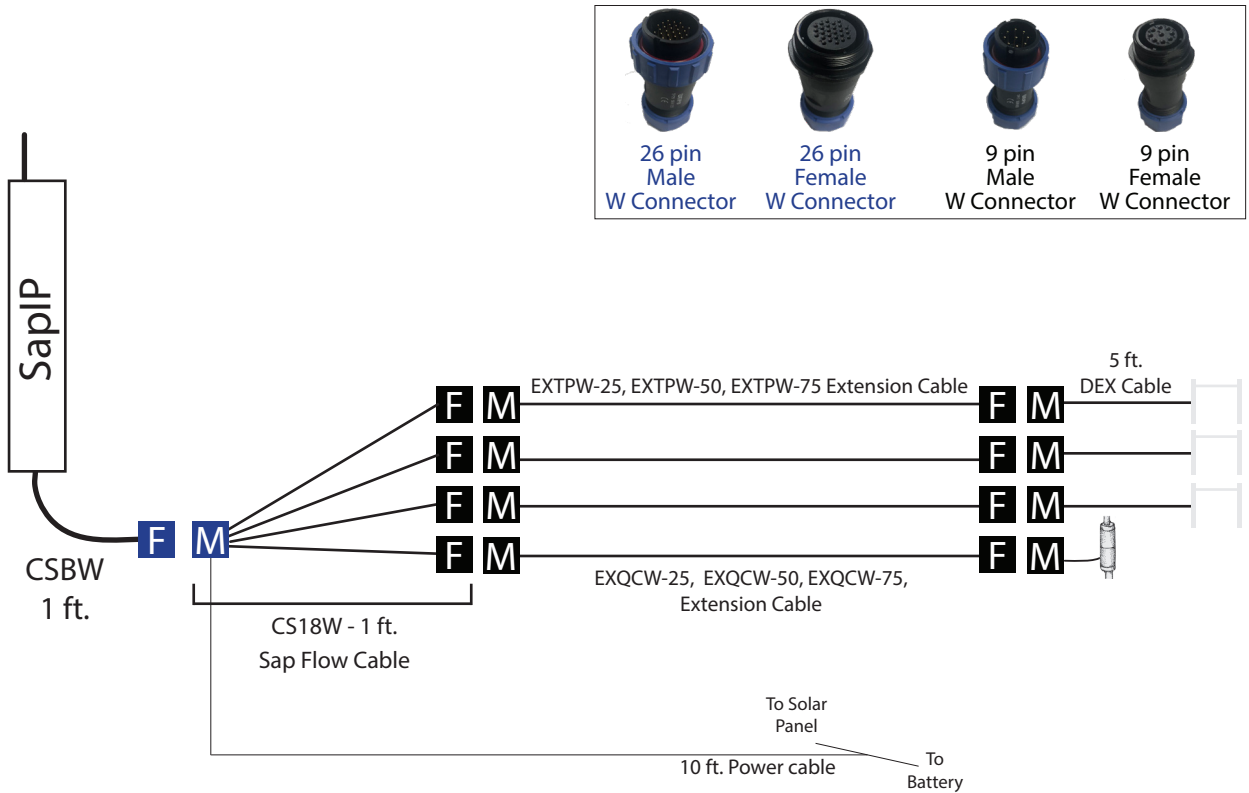



CS19W
Cable Set
(4) TDP10, 30, or 50
(2) SM150T Soil
Moisture

